

# 15', 20', & 25' HDF HEAVY DUTY DRILLS

from



This productive model is designed with a 2.4 bushel per foot seed box and 10 HD series openers. The 10HD openers feature parallel linkage with 15 inch 4 mil blades, 10 inches of travel, and heavy-duty down pressure springs to keep the opener firmly in the ground. The planter seed tube and heat treated blade separator ensure that the seed reaches the bottom of the well defined seed groove.

The 18-position T-handle depth control precisely sets the opener depth. Your choice of 2x13 or 3x13 single,

double 1x12 or double wedge style closing wheels firm the seed into moisture and completes the planting operation. Options include: Keeton seed firmers, Seed-Loc® wheels, unit mounted coulters, and row markers. These units also feature the simple, field proven, fluted feed metering system. A precision model is also available that offers singulation of a wide variety of seeds on every row.

**MODELS**  
**1510HDF**  
**2010HDF**  
**2510HDF**

## 10 SERIES HD (HEAVY DUTY) OPENER

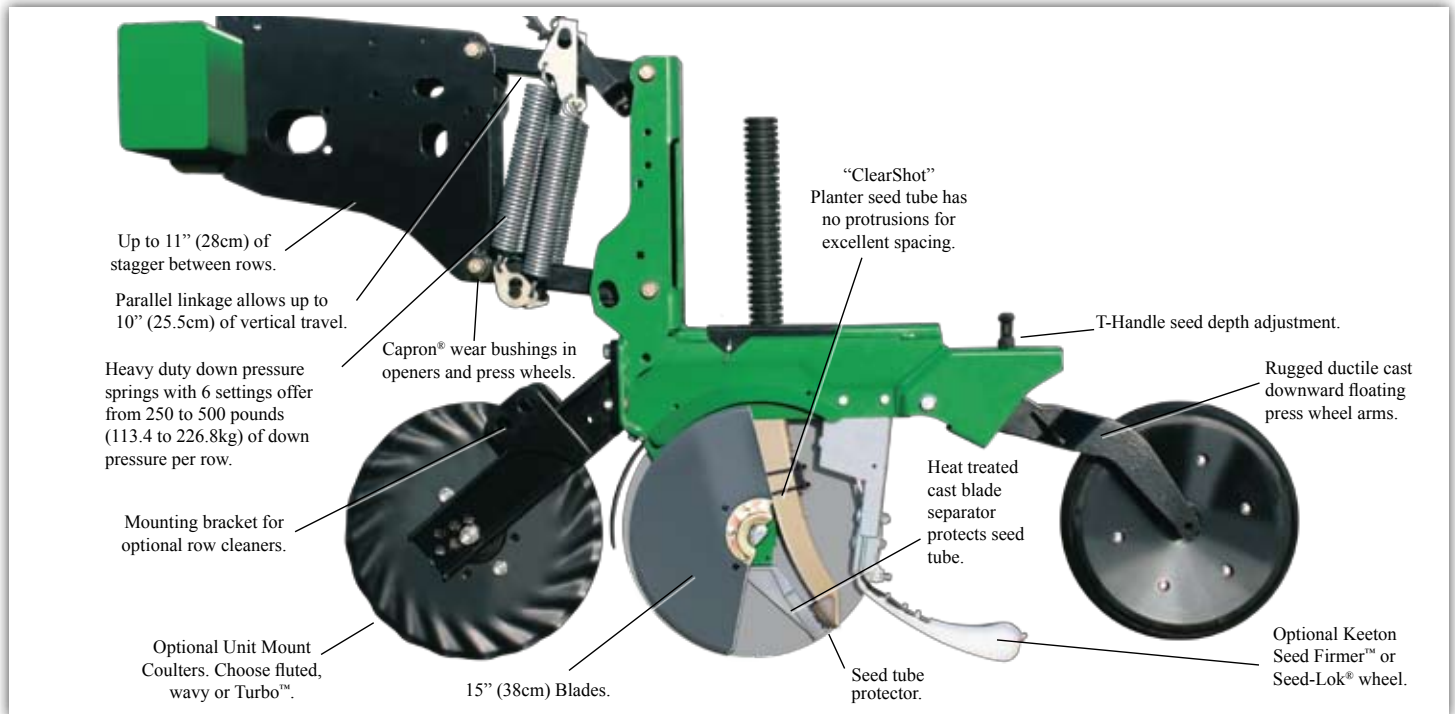

## PRESS WHEEL CHOICES



**2" x 13" Single (Conversion)**

This design presses soil directly over the seed, aggressively firming the soil.



**3" x 13" (7.6 x 33cm) Center Rib**

Provides excellent flotation and consistent depth control.



**1" x 12" (2.5 x 30.5cm) Double - V**

It provides excellent depth control in most soil conditions.



**Wedge** - This aggressive tapered edge design efficiently closes the seed trench and firms soil around the seed.



2510HDF Shown with Options

**FLUTED FEED CUP**



The exclusive Great Plains fluted feed cup delivers outstanding versatility. Whether the seed you are drilling is small, large or fragile, our time proven metering system will deliver the rate you choose, evenly and gently.

**GROUND DRIVE**



Straddle axle design maximizes strength and prevents gauge wheel arm twisting. It is also spring loaded to ensure proper contact with the ground on uneven irrigation beds. (2010HDF & 2510HDF only)

**SMALL SEEDS BOX (OPT)**



The optional smaller version of the fluted feed cup accurately meters small seeds.

**SPECIFICATIONS**

Model Name	1510HDF	2010HDF	2510HDF
Row Spacing, Inches	10", 7.5"	10", 7.5"	15", TR30, 10", 7.5"
Weight, Pounds	4200, 4950 lbs.	5860, 6820 lbs.	6180, 6180, 7305, 8680 lbs.
Transport Width	15' 1" (4.6m)	20' 1" (6.4m)	25' 2" (7.67m)
Gauge Wheel Tires	9.5Lx15 8-ply	11L-15SL 12-Ply (11L-15SL 8-Ply Duals)	11L-15SL 12-Ply (11L-15SL 8-Ply Duals)
Small Seeds Box Capacity	0.24/ft 3.6 bu (127 liter)	0.24/ft 4.8 bu (169 liter)	0.24/ft 5.8 bu (204 liter)
Seed Box Capacity	36 bu (1269 liter)	48 bu (1691 liter)	57 bu (2112 liter)

**OPTIONS**

- Press Wheels
- Fertilizer Attachment (15' & 20' only)
- Markers
- Fluted Seed Cup Plugs
- Small Seeds Box
- Unit Mount Coulters

Note: All specifications subject to change without notice.  
\*Not all options available on all models