

Installation Instructions



Full Press Drill Post Conversion Update

Used with:

- 30' 3-Section Full Press Drill
- 30' High Clearance Full Press Drill



When you see this symbol, the subsequent instructions and warnings are serious - follow without exception. Your life and the lives of others depend on it!

General Information

These instructions explain how to install the Full Press Post Conversion Kit.

These instructions apply to:

104-008A	RH Full Press Post and Conv. Kit
104-009A	LH Full Press Post and Conv. Kit
104-011K	RH Full Press Conv. Kit
104-012K	LH Full Press Conv. Kit

Manual Update

Refer to the Full Press Drill operator's manual for detailed information on safely operating, adjusting, troubleshooting and maintaining the Full Press Post Conversion. Refer to the parts manual for part identification.

105-100M	Operator's/Parts Manual
129-035M	Operator's Manual
129-035P	Parts Manual

Before You Start

Pages 6 and 7 are a detailed listing of parts included in the Full Press Post Conversion package. Use this list to inventory parts received.

Tools Required

- Basic hand tools
- Acetylene torch
- Welder
- Grinder

Definitions

Right-hand and left-hand as used in this manual are determined by facing the direction the machine will travel while in use unless otherwise stated.



CAUTION!

Use caution when using tools which emit sparks such as torches, welders and grinders. Do not use spark emitting tools in areas where flammable or explosive materials may be present. Do not allow anyone to enter into the path of sparks.

Note: These instructions are written with the assumption that the existing pivot post is in usable condition and does not need replaced. This requires kits 104-011K and 104-012K.

If the existing pivot post needs replaced order kits 104-008A and 104-009A and skip steps 14 through 22.

Assembly Instructions

1. Remove the left-hand drill box from the left-hand pivot post.
2. Remove the left-hand hydraulic cylinder.
3. Remove the left-hand pivot post from the drill main frame.

Refer to Figure 1

4. Measure $12 \frac{25}{32}$ " from the front surface of square tube (1) towards the outer end of square tube (2).

Note: Cut tube a little longer to allow for grinding to make the end square.

5. Using a torch, carefully cut tube (2).
6. Grind the surfaces of the square tube smooth.

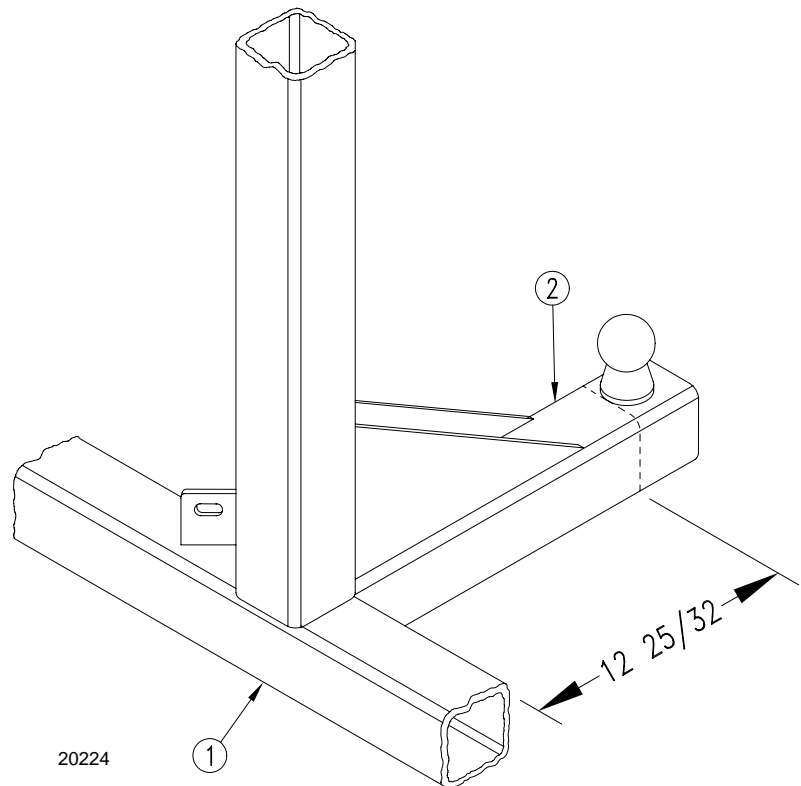

Figure 1
Remove Old Pivot Ball

Refer to Figure 2

7. Place the spindle hub assembly (1) on the top surface of the square tube (2). Measure from the center point of the spindle hub assembly to the front surface of the square tube $13 \frac{7}{8}$ ".
8. Use the spindle hub assembly as a template to mark where to cut a saddle into the square tube.
9. Use a torch to make a saddle cut in the square tube and smooth the surfaces with a grinder.

Note: Be careful when using the spindle hub as a template, there are bearing cups on the inside. Do not use as a jig for torching the saddle cut.

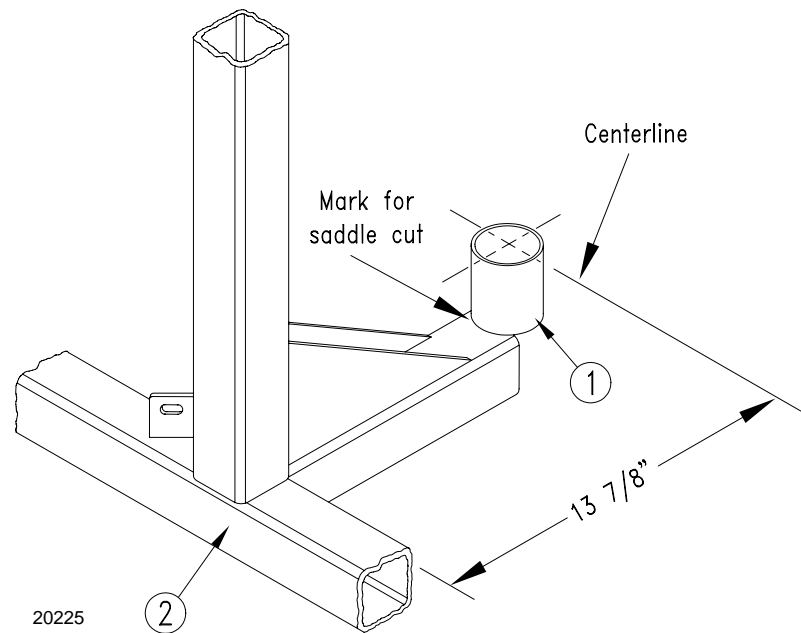

Figure 2
Marking for the Saddle Cut

Refer to Figure 3

10. Center the spindle hub assembly (1) on the square tube where the saddle cut was made. Position the hub so the top edge is raised 1/4" above the top surface of the tube. Make sure the centerline of the hub is 13 7/8" from the front surface of the square tube.
11. Clamp the spindle hub assembly (1) in place and make sure it is plum with the upright square tube (2). Clamp only to the outside of the hub.

Note: Make sure the measurements are accurate and the hub is plum with the tube. Securely clamp the hub in place before welding.

12. Cover the openings of the spindle hub assembly (1) so not to allow any welding sparks or beads to get inside. This is necessary in order to protect the bearing cups on the inside of the hub.
13. Weld the spindle hub assembly (1) in place using a weld with high tensile strength.

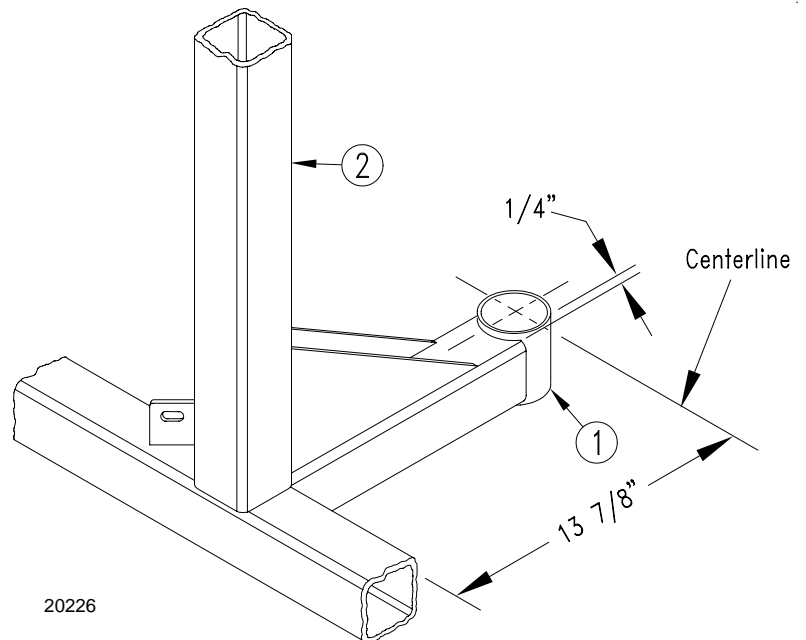

Figure 3
Spindle Hub Assembly

Refer to Figure 4

14. If you are reusing the pivot post (1) it will be necessary to remove the old pivot bracket (2).
15. After removing old bracket (2) smooth the surfaces of the pivot post (1).

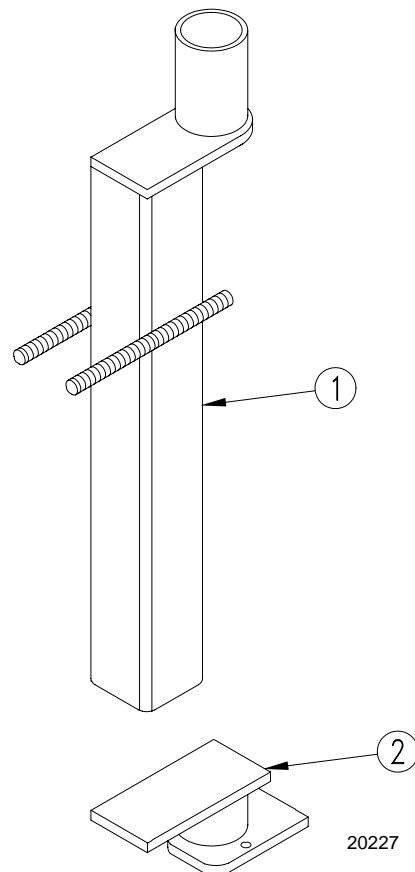

Figure 4
Pivot Post

4 | Post Conversion Update

Refer to Figure 5

16. Attach the U-joint post side plates (1) to opposite sides of the old pivot post (2). Place the plates with their holes down and extending out in the same direction as the round pivot tube (3) on top.
17. Measure $31 \frac{7}{16}$ " from the top edge of the round pivot tube (3) to the centerline of the U-joint post side plates (1). Measure back $\frac{1}{8}$ " from the front edge of the old pivot post (2) to the centerline of the U-joint post side plates (1).
18. Clamp U-joint post side plates (1) to the old pivot post (2) and recheck your measurements before welding.
19. Insert the $6 \frac{3}{4}$ " long post pivot bolt (4) through the holes in the U-joint post side plates (1). The bolt should move freely, if not, check your measurements.
20. Hold the $\frac{1}{4}$ " square key (5) against the plate (1) and head of bolt (4). Tack weld it to the plate. This will keep the bolt from turning while tightening the nut later.
21. Remove the bolt (4).
22. Weld U-joint post side plates (1) and $\frac{1}{4}$ " square key in place using a weld with high tensile strength.

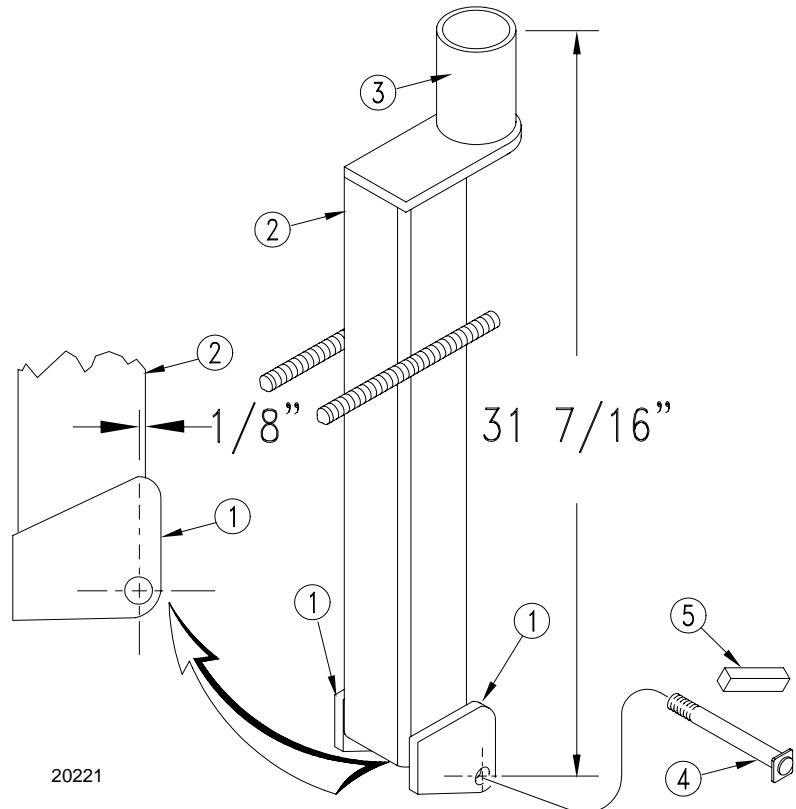

Figure 5
Old Pivot Post

Refer to Figure 6

23. After allowing the spindle hub assembly (1) to cool, remove any dirt or foreign material which might have gotten inside.
24. Pack the top bearing cone (2) with wheel bearing grease and insert it in the top of the spindle hub assembly (1).
25. Install the grease seal (3) and insert the left-hand U-joint spindle (4).
26. Pack the bottom bearing cone (5) with wheel bearing grease and insert it in the bottom of the spindle hub assembly (1).
27. Install the $\frac{7}{8}$ " flat washer (6) and thread on the $\frac{7}{8}$ " slotted hex nut (7). Snug the nut (7) while moving the U-joint spindle (4) back and forth. After the snugging the nut back it off about $\frac{1}{2}$ a turn. Line one of the slots in the nut (7) with the hole in the U-joint spindle (4) and insert the cotter pin (8).
28. Install the hub cap (9) on the spindle hub assembly (1).

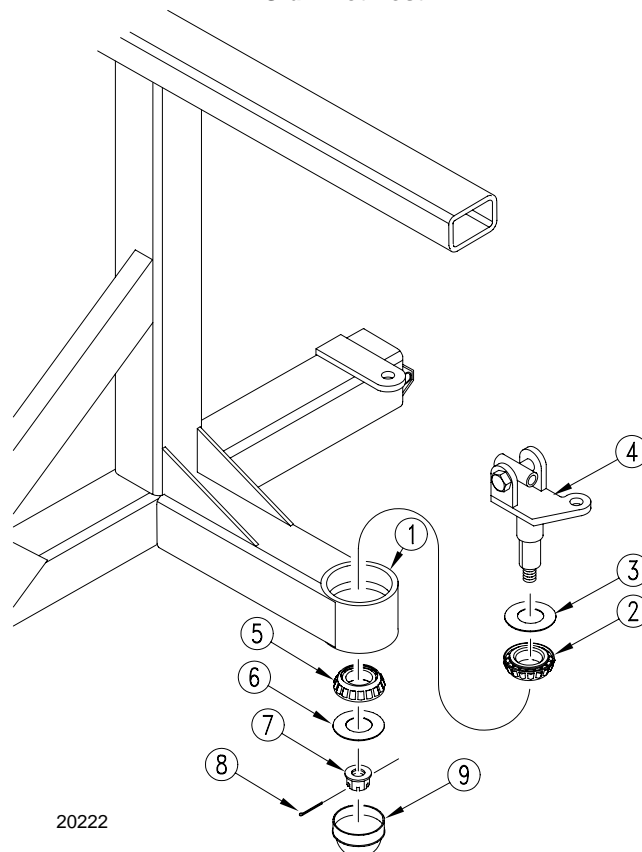
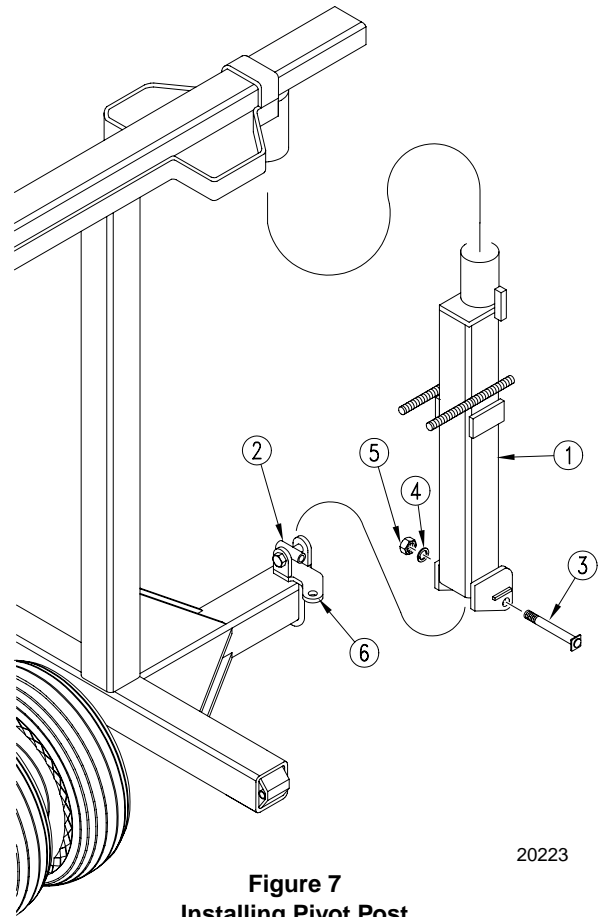

Figure 6
Spindle Hub Assembly

Refer to Figure 7

29. Install the top round tube of the pivot post (1) into the pivot post cap on the main drill frame.
30. Rotate the U-joint spindle (2) so the hole for the cylinder clevis (6) is facing towards the closing cylinder lug (7).
31. Align the holes in the U-joint post side plates on the pivot post (1) with the U-joint spindle (2).
32. Insert the 6 3/4" long pivot bolt (3) and position it so the head rests against the 1/4" square key so the bolt will not turn while being tightened. Secure bolt with the 1 1/4" lock washer (4) and 1 1/4" hex nut (5). Tighten nut.

*Refer to Figure 8*

33. Place the closing cylinder lug (1) on top of square tube (2).
34. From the centerline of the hole in the closing cylinder lug (1) measure 16 7/8" to the centerline of the square tube (3). Measure from the centerline of the lug (1) 1 3/8" to the edge of the square tube (2).
35. Clamp lug (1) and weld in place using a high tensile strength weld.
36. Reinstall the hydraulic cylinder.
37. Reattach the left-hand drill box to the pivot post.
38. Repeat the procedure to install the pivot post conversion kit on the right-hand side of the drill substituting right for left.

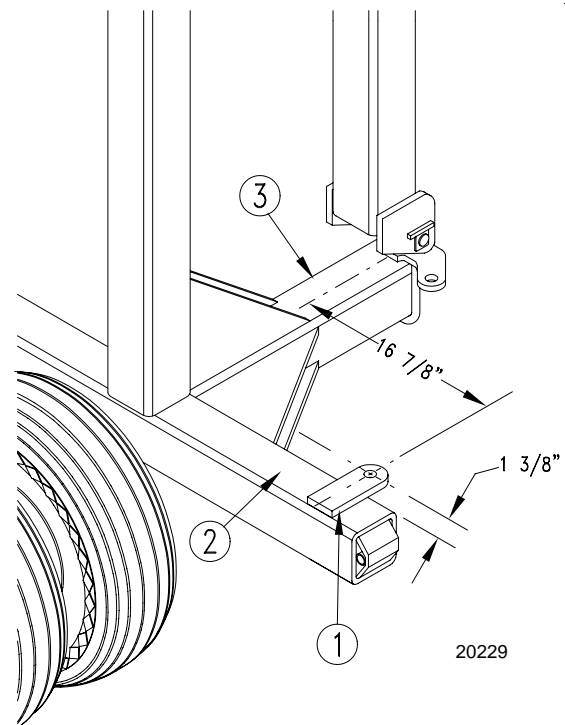

104-008A RH FULL PRESS POST AND CONV KIT

Your kit includes:

Qty.	Part No.	Part Description
1	104-011K	RH FULL PRESS CONV KIT
1	128-002H	HC POST WELDED ASSEMBLY RH

104-009A LH FULL PRESS POST AND CONV KIT

Your kit includes:

Qty.	Part No.	Part Description
1	104-012K	LH FULL PRESS POST KIT
1	128-001H	HC POST WELDED ASSEMBLY LH

104-011K RH FULL PRESS POST CONV KIT

Your kit includes:

Qty.	Part No.	Part Description
1	104-010M	MANUAL FULL PRESS POST CON
1	109-031D	JACK SHAFT - KEY
1	125-001H	U JOINT SPINDLE RH
1	125-005S	SPINDLE HUB ASSEMBLY
1	125-066D	CLOSING CYLINDER LUG
2	128-053D	U-JOINT POST SIDE PLATE
1	156-022H	POST PIVOT BOLT
1	800-001C	GREASE ZERK STRAIGHT 1/4-28
1	803-029C	NUT HEX SLOTTED 7/8-14 PLT
1	803-034C	NUT HEX 1 1/4-7 PLT
1	804-026C	WASHER FLAT 7/8 SAE PLT
1	804-030C	WASHER LOCK 1 1/4 SPRING PLT
1	805-016C	PIN COTTER 3/16 X 1 1/4 PLT
1	816-012C	SEAL 3.375 X 2.0 X.438 CR2
1	822-014C	BEARING CONE 25590
1	822-016C	BEARING CONE 25877
1	890-032C	HUB CAP

104-012K LH FULL PRESS CONVERSION KIT

Your kit includes:

Qty.	Part No.	Part Description
1	104-010M	MANUAL FULL PRESS POST CON
1	109-031D	JACK SHAFT - KEY
1	125-002H	U JOINT SPINDLE LH
1	125-005S	SPINDLE HUB ASSEMBLY
1	125-066D	CLOSING CYLINDER LUG
2	128-053D	U-JOINT POST SIDE PLATE
1	156-022H	POST PIVOT BOLT
1	800-001C	GREASE ZERK STRAIGHT 1/4-28
1	803-029C	NUT HEX SLOTTED 7/8-14 PLT
1	803-034C	NUT HEX 1 1/4-7 PLT
1	804-026C	WASHER FLAT 7/8 SAE PLT
1	804-030C	WASHER LOCK 1 1/4 SPRING PLT
1	805-016C	PIN COTTER 3/16 X 1 1/4 PLT
1	816-012C	SEAL 3.375 X 2.0 X.438 CR2
1	822-014C	BEARING CONE 25590
1	822-016C	BEARING CONE 25877
1	890-032C	HUB CAP