

Installation Instructions



3-Point Precision Seeding System Marker Option

Used with:

- 1510P and 1520P
- 2010P and 2020P



When you see this symbol, the subsequent instructions and warnings are serious - follow without exception. Your life and the lives of others depend on it!

General Information

These instructions explain how to install the Marker Option on the 15 and 20 foot 3-point Precision Seeding Systems.

The markers fold and unfold hydraulically for field operation. The marker disks leave a line for the drill operator to follow on the next field pass. Markers are mounted on the drill frame and require two hydraulic remote valves on the tractor. A sequence valve is available so markers can be operated on one hydraulic circuit.

These instructions apply to:

113-691A	15P Single LH Marker Package
113-692A	15P Dual Marker Package
113-693A	20P Single LH Marker Package
113-694A	20P Dual Marker Package

Manual Update

Refer to the 3-Point Precision Seeding System operator's manual for detailed information on safely operating, adjusting, troubleshooting and maintaining the Marker Option. Refer to the parts manual for part identification.

118-732M	1510P and 1520P Operator's Manual
118-732P	1510P and 1520P Parts Manual
118-740M	2010P and 2020P Operator's Manual
118-740P	2010P and 2020P Parts Manual

Before You Start

Page 7 is a detailed listing of parts included in the Marker Option package. Use this list to inventory parts received.

Assembly Instructions

Marker Assembly

Refer to Figure 1.

1. Lower drill into field position. Allow 9 feet on each end of a 15-foot drill and 11 feet on each end of a 20-foot drill for marker assembly.
2. Mount first marker section (1) on drill 7 x 5 inch frame tube (2). Mount marker at the end of the drill using dimension "A" as a starting point. Some row spacings will require the mount to be adjusted in or out from this starting point.
3. Secure marker section with 5/8 inch u-bolts (3), lock washers, washers and nuts (4), and 1/2 inch u-bolts (5), lock washers and nuts (6).

NOTE: On the 20-foot drill with 15 inch row spacing, the last opener is bolted to the marker mount using 5/8 x 6 1/2 inch straight bolts (7).

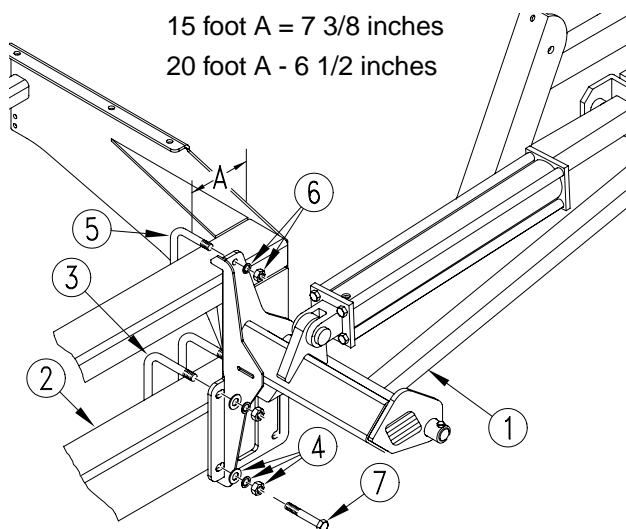

Figure 1
First Marker Section Assembly

18413

2 | Marker Option

Refer to Figure 2

4. Remove port plugs on cylinder and carefully unfold first marker section. Rotate hinge section (7) into a horizontal position.
5. Align holes of break-away section (8) with holes in hinge section. Bolt sections together using a 5/8-inch pivot bolt (9), lock nut (10), 3/8-by-1 3/4-inch, grade 2 shear bolt (11) and lock nut (12).

IMPORTANT: Be sure shear bolt is a grade 2 bolt. Failure to use a grade 2 bolt can cause marker damage.

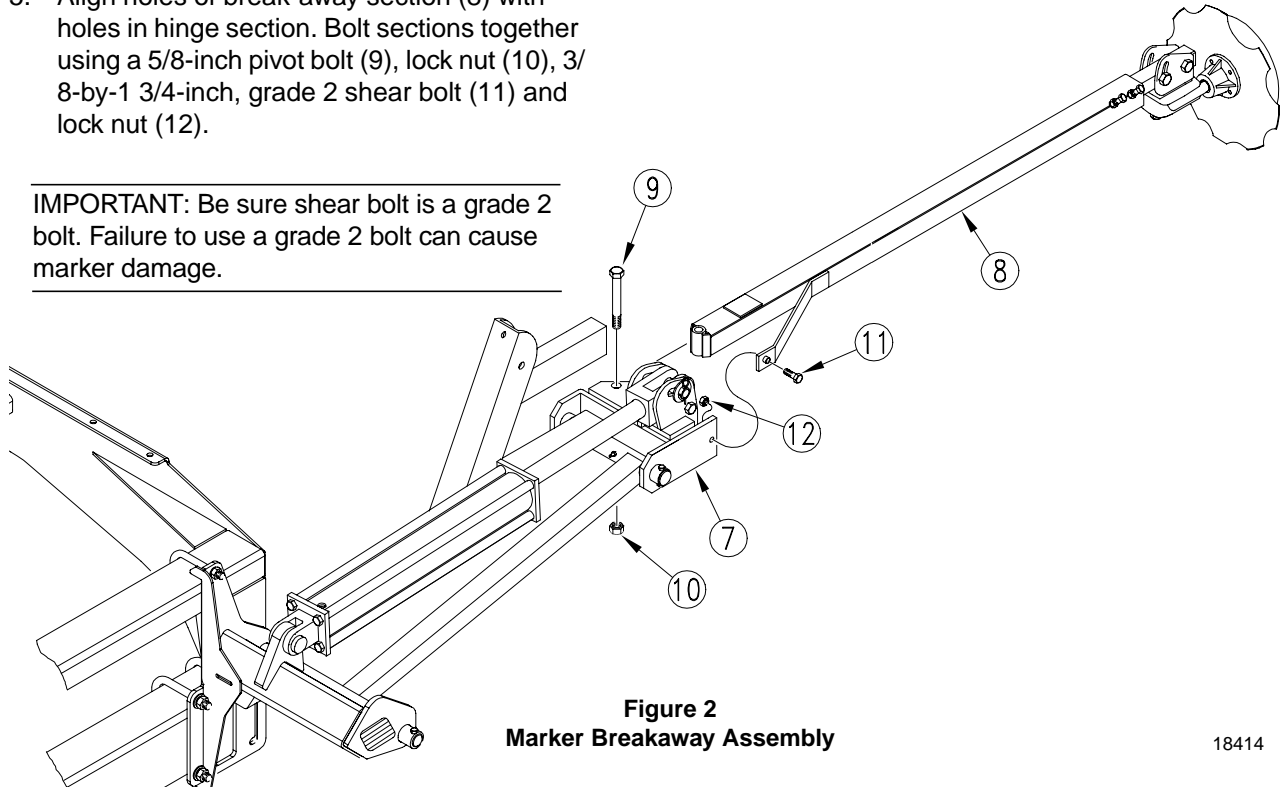

Figure 2
Marker Breakaway Assembly

18414

6. Repeat steps for other marker.
7. To adjust markers, refer to *Marker Adjustments* in the operator's manual.

Carrier Assembly for 20P drill

To assemble carrier onto drill frame, refer to Figure 3.

1. Assemble transport-carrier mount (1) on drill frame. Center mount 49 inches from outside end of drill frame. Use $1/2 \times 6 \ 1/32 \times 7$ -inch u-bolts (2), flat washers, lock washers and hex nuts (3). Slide mount forward so its leading edge is about $2 \ 1/4$ inches ahead of front edge of drill frame tube.
2. Bolt transport carrier (4) to transport-carrier mount so top surface of saddle (5) is about $29 \ 1/4$ inches above top of drill frame tube. Secure transport carrier with $1/2 \times 2 \times 3$ -inch u-bolts (6), lock washers and hex nuts (7).
3. After installing and bleeding hydraulics, transport carrier may require further adjustment. When folded, the second marker section should rest in the transport-carrier saddle.

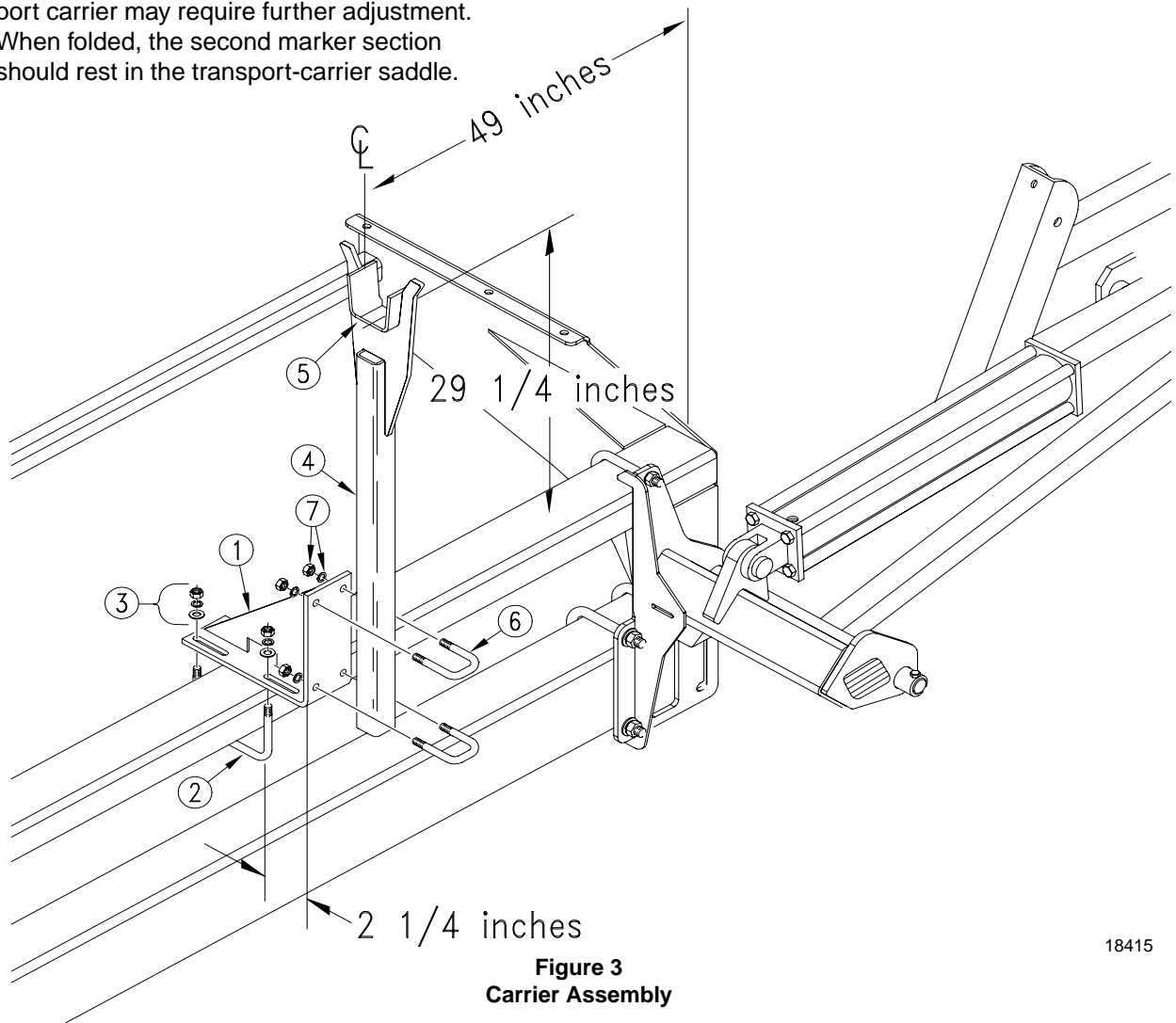

Figure 3
Carrier Assembly

18415

Installing Marker Hydraulics

Without Sequence Valve

Refer to Figure 4.

1. Install elbow fittings (1) in cylinder ports.
2. At rod end of each cylinder, install an adaptor (2) into elbow fitting. Install a needle valve (3) in adaptor.
3. Connect hydraulic hoses to fittings and route hydraulic hoses to tractor outlets. Route hydraulic hoses through transport-carrier mount at cutout. Use black cable ties to secure hydraulic hoses to drill frame.
4. Using orange cable ties, secure a plastic hose label, see Figure 5, to each pair of hydraulic hoses near tractor outlets.
5. Proceed with "Bleeding Marker Hydraulics" on page 6.

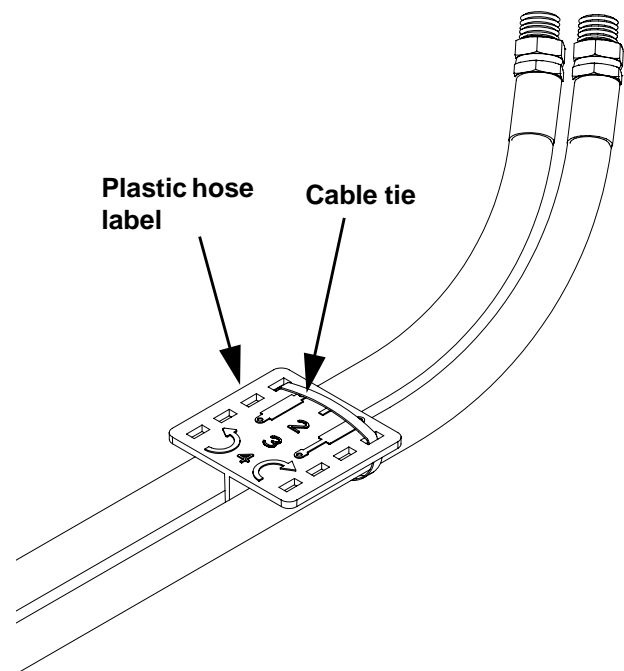

Figure 5
Hose label and cable tie

17641

With Sequence Valve

Refer to Figure 6.

1. Mount sequence valve (1) on drill using mounting plate (2). Bolt plate to inside end of left-hand-box panel (3) using one 1/2-inch hex bolt (4).
2. Bolt valve to mounting plate with two 3/8 x 3/4-inch hex bolts and lock washers (5).
3. Install elbow fittings in cylinder ports. Discard adaptor fitting and two needle valves provided in marker kit.
4. Use hoses provided to connect valve ports to cylinders. Refer to Figure 7 for port connections.
5. Connect your own hydraulic hoses to ports on front of valve. Route hoses to tractor outlets.
6. Using orange cable tie, secure plastic hose label, see Figure 5, to hydraulic hoses near tractor outlets.
7. Proceed with "Bleeding Marker Hydraulics" on page 6.

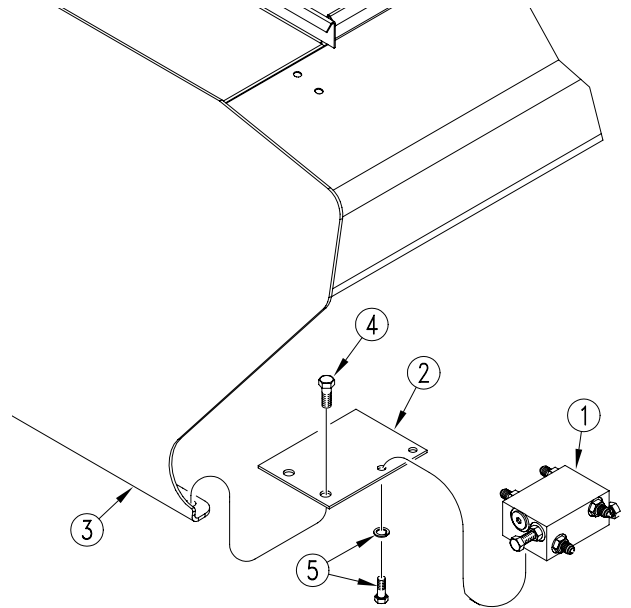

Figure 6
Sequence Valve Assembly

18416

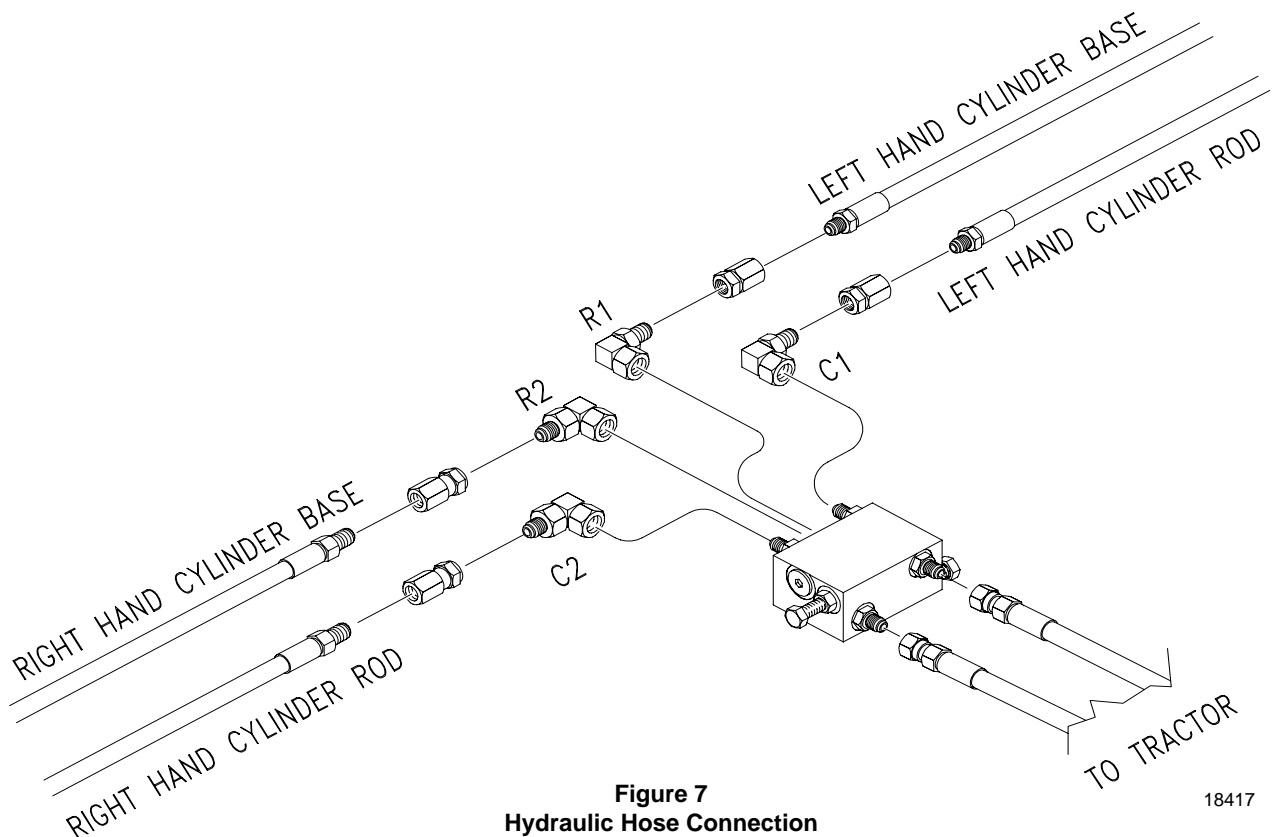

Figure 7
Hydraulic Hose Connection

18417

Bleeding Marker Hydraulics



CAUTION!

You may be injured if hit by a folding or unfolding marker. Markers may fall quickly and unexpectedly if the hydraulics fail. Never allow anyone near the drill when folding or unfolding the markers.



WARNING!

Escaping fluid under pressure can have sufficient pressure to penetrate the skin. Check all hydraulic lines and fittings before applying pressure. Fluid escaping from a very small hole can be almost invisible. Use paper or cardboard, not body parts, and wear heavy gloves to check for suspected leaks. If injured, seek medical assistance from a doctor that is familiar with this type of injury. Foreign fluids in the tissue must be surgically removed within a few hours or gangrene will result.

1. Check that tractor hydraulic reservoir is full.
2. With both markers lowered into field position, loosen hydraulic-hose fittings at rod and base ends of marker cylinders. If applicable, loosen fittings on back side of sequence valve.

IMPORTANT: Never bleed an O-ring fitting. Instead, bleed a nearby pipe or JIC fitting.

3. With tractor idling, activate tractor hydraulic valve until oil seeps out around a loosened fitting. Tighten that fitting.

IMPORTANT: JIC fittings do not require high torque. JIC and O-ring fittings do not require sealant. Always use liquid pipe sealant when adding or replacing pipe-thread fittings. To avoid cracking hydraulic fittings from over tightening, do not use plastic sealant tape.

4. Reactivate tractor hydraulic valve until oil seeps out around another loosened fitting. Tighten that fitting. Repeat process until all loosened fitting have been bled and tightened.
5. Adjust marker folding to a safe speed. Refer to "Marker Adjustments" in the operator's manual.

113-691A MARKER, 3PT 15-P SINGLE LH

Your kit includes:

Qty.	Part No.	Part Description
1	811-017C	HH1/4R1 156 3/8MNPT 1/2MNP
1	811-300C	HH1/4R1 176 3/8MNPT 1/2MNP
1	113-180H	LH FIRST SECTION
1	113-191H	2 SECTION MARKER BREAKAWAY
1	113-248D	PIN 1 OD X 4.34 USABLE
1	113-312D	FIRST PIVOT SHAFT
1	113-313D	SECOND PIVOT SHAFT
1	113-324D	CYLINDER STOP
2	113-325D	STOP BUSHING
1	113-351D	MARKER TUBE 42 LG
1	113-468H	LIFT LUG CHANNEL L.H.
2	113-491D	ADJUST MOUNT SPACER TUBE
1	113-503H	MARKER DISK ADJUST MOUNT
1	113-563S	MARKER DISC & HUB ASSEMBLY
1	113-689H	MARKER MOUNT LH
2	800-001C	GREASE ZERK STRAIGHT 1/4-28
2	801-054C	SCREW SET SQ HD 1/2-13X1 GR5
4	802-099C	HHCS 1/2-13X3 1/4 GR5
2	802-115C	HHCS 5/16-18X2 GR5
1	802-249C	HHCS 1/2-13X4 1/2 GR5 SPTHD
1	802-253C	HHCS 3/8-16X1 3/4 GR2
1	802-254C	HHCS 5/8-11X5 1/2 GR5
2	803-011C	NUT LOCK 5/16-18 PLT
1	803-013C	NUT LOCK 3/8-16 PLT
1	803-019C	NUT LOCK 1/2-13 PLT
4	803-020C	NUT HEX 1/2-13 PLT
1	803-024C	NUT LOCK 5/8-11 PLT
2	803-036C	NUT HEX JAM 1/2-13 PLT
4	804-015C	WASHER LOCK SPRING 1/2 PLT
4	804-017C	WASHER FLAT 1/2 USS PLT
2	804-029C	WASHER FLAT 1 SAE
2	805-058C	PIN COTTER 3/16 X 2
1	810-205C	CYL 2X20X1.12 ROD (TIE) 1
1	818-229C	DECAL AMBER REFLECTOR
2	818-682C	DECAL WARNING PINCH/CRUSH MRKR
2	803-020C	NUT HEX 1/2-13 PLT
4	803-021C	NUT HEX 5/8-11 PLT
2	804-015C	WASHER LOCK SPRING 1/2 PLT
4	804-021C	WASHER FLAT 5/8 SAE PLT
4	804-022C	WASHER LOCK SPRING 5/8 PLT
2	806-053C	U-BOLT 5/8-11 X 7 1/32 X 6 1/2
1	806-122C	U-BOLT 1/2-13 X 3 1/32 X 6
1	810-058C	VALVE 3/8 NEEDLE
1	811-044C	AD 3/8MNPT
2	811-281C	EL 3/8FNPT 9/16MORB

8 Marker Option

113-692A MARKER, 3PT 15-P DUAL

Your kit includes:

Qty.	Part No.	Part Description
2	811-017C	HH1/4R1 156 3/8MNPT 1/2MNP
2	811-300C	HH1/4R1 176 3/8MNPT 1/2MNP
1	113-180H	LH FIRST SECTION
1	113-188H	RH FIRST SECTION
2	113-191H	2 SECTION MARKER BREAKAWAY
2	113-248D	PIN 1 OD X 4.34 USABLE
2	113-312D	FIRST PIVOT SHAFT
2	113-313D	SECOND PIVOT SHAFT
2	113-324D	CYLINDER STOP
4	113-325D	STOP BUSHING
2	113-351D	MARKER TUBE 42 LG
1	113-467H	LIFT LUG CHANNEL R.H.
1	113-468H	LIFT LUG CHANNEL L.H.
4	113-491D	ADJUST MOUNT SPACER TUBE
2	113-503H	MARKER DISK ADJUST MOUNT
2	113-563S	MARKER DISC & HUB ASSEMBLY
1	113-689H	MARKER MOUNT LH
1	113-690H	MARKER MOUNT RH
4	800-001C	GREASE ZERK STRAIGHT 1/4-28
4	801-054C	SCREW SET SQ HD 1/2-13X1 GR5
8	802-099C	HHCS 1/2-13X3 1/4 GR5
4	802-115C	HHCS 5/16-18X2 GR5
2	802-249C	HHCS 1/2-13X4 1/2 GR5 SPTHD
2	802-253C	HHCS 3/8-16X1 3/4 GR2
2	802-254C	HHCS 5/8-11X5 1/2 GR5
4	803-011C	NUT LOCK 5/16-18 PLT
2	803-013C	NUT LOCK 3/8-16 PLT
2	803-019C	NUT LOCK 1/2-13 PLT
12	803-020C	NUT HEX 1/2-13 PLT
2	803-024C	NUT LOCK 5/8-11 PLT
4	803-036C	NUT HEX JAM 1/2-13 PLT
12	804-015C	WASHER LOCK SPRING 1/2 PLT
12	804-017C	WASHER FLAT 1/2 USS PLT
4	804-029C	WASHER FLAT 1 SAE
4	805-058C	PIN COTTER 3/16 X 2
2	810-205C	CYL 2X20X1.12 ROD (TIE) 1 PIN
2	818-229C	DECAL AMBER REFLECTOR
4	818-682C	DECAL WARNING PINCH/CRUSH
4	803-020C	NUT HEX 1/2-13 PLT
8	803-021C	NUT HEX 5/8-11 PLT
4	804-015C	WASHER LOCK SPRING 1/2 PLT
8	804-021C	WASHER FLAT 5/8 SAE PLT
8	804-022C	WASHER LOCK SPRING 5/8 PLT
4	806-053C	U-BOLT 5/8-11 X 7 1/32 X 6 1/2
2	806-122C	U-BOLT 1/2-13 X 3 1/32 X 6
2	810-058C	VALVE 3/8 NEEDLE
2	811-044C	AD 3/8MNPT
4	811-281C	EL 3/8FNPT 9/16MORB
1	113-666D	MARKER REVERSING ADAPT PLATE 1
1	113-667D	MARKER REVERSING ADAPT PLATE 2
2	802-041C	HHCS 1/2-13X3 1/2 GR5

113-693A MARKER, 3-PT 20-P SINGLE LH

Your kit includes:

Qty.	Part No.	Part Description
1	811-015C	HH1/4R1 192 3/8MNPT 1/2MNPT
1	811-297C	SP HH1/4R1 212 3/8MNPT-W/AD
1	113-180H	LH FIRST SECTION
1	113-248D	PIN 1 OD X 4.34 USABLE
1	113-312D	FIRST PIVOT SHAFT
1	113-313D	SECOND PIVOT SHAFT
1	113-324D	CYLINDER STOP
2	113-325D	STOP BUSHING
1	113-354D	13' MARKER TUBE 46 1/2 LONG
1	113-468H	LIFT LUG CHANNEL L.H.
2	113-491D	ADJUST MOUNT SPACER TUBE
1	113-503H	MARKER DISK ADJUST MOUNT
1	113-563S	MARKER DISC & HUB ASSEMBLY
1	113-646H	20' MARKER BREAKAWAY
1	113-689H	MARKER MOUNT LH
2	800-001C	GREASE ZERK STRAIGHT 1/4-28
2	801-054C	SCREW SET SQ HD 1/2-13X1 GR5
4	802-099C	HHCS 1/2-13X3 1/4 GR5
2	802-115C	HHCS 5/16-18X2 GR5
1	802-249C	HHCS 1/2-13X4 1/2 GR5 SPTH
1	802-253C	HHCS 3/8-16X1 3/4 GR2
1	802-254C	HHCS 5/8-11X5 1/2 GR5
2	803-011C	NUT LOCK 5/16-18 PLT
1	803-013C	NUT LOCK 3/8-16 PLT
1	803-019C	NUT LOCK 1/2-13 PLT
4	803-020C	NUT HEX 1/2-13 PLT
1	803-024C	NUT LOCK 5/8-11 PLT
2	803-036C	NUT HEX JAM 1/2-13 PLT
4	804-015C	WASHER LOCK SPRING 1/2 PLT
4	804-017C	WASHER FLAT 1/2 USS PLT
2	804-029C	WASHER FLAT 1 SAE
1	805-058C	PIN COTTER 3/16 X 2
1	810-205C	CYL 2X20X1.12 ROD (TIE) 1 PIN
1	818-229C	DECAL AMBER REFLECTOR
2	818-682C	DECAL WARNING PINCH/CRUSH
1	113-568H	MARKER TRANSPORT MOUNT
1	113-677H	20 BM MARKER TRANSPORT CARRIER
4	800-035C	CABLE TIE 28 LONG
4	802-335C	HHCS 5/8-11X6 1/2 GR5
10	803-020C	NUT HEX 1/2-13 PLT
4	803-021C	NUT HEX 5/8-11 PLT
2	803-036C	NUT HEX JAM 1/2-13 PLT
10	804-015C	WASHER LOCK SPRING 1/2 PLT
4	804-017C	WASHER FLAT 1/2 USS PLT
4	804-021C	WASHER FLAT 5/8 SAE PLT
4	804-022C	WASHER LOCK SPRING 5/8 PLT
2	806-005C	U-BOLT 1/2-13 X 2 X 3 GR 5
2	806-053C	U-BOLT 5/8-11 X 7 1/32 X 6 1/2
1	806-122C	U-BOLT 1/2-13 X 3 1/32 X 6
2	806-159C	U-BOLT 1/2-13 X 5 1/32 X 4
1	810-058C	VALVE 3/8 NEEDLE
1	811-044C	AD 3/8MNPT
2	811-281C	EL 3/8FNPT 9/16MORB

10 Marker Option

113-694A MARKER, 3PT 20-P DUAL

Your kit includes:

Qty.	Part No.	Part Description
2	811-015C	HH1/4R1 192 3/8MNPT 1/2MNPT
2	811-297C	SP HH1/4R1 212 3/8MNPT-W/AD
1	113-597V	20' DUAL FF HOSE BUNDLE
1	113-180H	LH FIRST SECTION
1	113-188H	RH FIRST SECTION
2	113-248D	PIN 1 OD X 4.34 USABLE
2	113-312D	FIRST PIVOT SHAFT
2	113-313D	SECOND PIVOT SHAFT
2	113-324D	CYLINDER STOP
4	113-325D	STOP BUSHING
2	113-354D	13' MARKER TUBE 46 1/2 LONG
1	113-467H	LIFT LUG CHANNEL R.H.
1	113-468H	LIFT LUG CHANNEL L.H.
4	113-491D	ADJUST MOUNT SPACER TUBE
2	113-503H	MARKER DISK ADJUST MOUNT
2	113-563S	MARKER DISC & HUB ASSEMBLY
2	113-646H	20' MARKER BREAKAWAY
1	113-689H	MARKER MOUNT LH
1	113-690H	MARKER MOUNT RH
4	800-001C	GREASE ZERK STRAIGHT 1/4-28
4	801-054C	SCREW SET SQ HD 1/2-13X1 GR5
8	802-099C	HHCS 1/2-13X3 1/4 GR5
4	802-115C	HHCS 5/16-18X2 GR5
2	802-249C	HHCS 1/2-13X4 1/2 GR5 SPTHD
2	802-253C	HHCS 3/8-16X1 3/4 GR2
2	802-254C	HHCS 5/8-11X5 1/2 GR5
4	803-011C	NUT LOCK 5/16-18 PLT
2	803-013C	NUT LOCK 3/8-16 PLT
2	803-019C	NUT LOCK 1/2-13 PLT
12	803-020C	NUT HEX 1/2-13 PLT
2	803-024C	NUT LOCK 5/8-11 PLT
4	803-036C	NUT HEX JAM 1/2-13 PLT
12	804-015C	WASHER LOCK SPRING 1/2 PLT
12	804-017C	WASHER FLAT 1/2 USS PLT
4	804-029C	WASHER FLAT 1 SAE
4	805-058C	PIN COTTER 3/16 X 2
2	810-205C	CYL 2X20X1.12 ROD (TIE) 1 PIN
2	818-229C	DECAL AMBER REFLECTOR
4	818-682C	DECAL WARNING PINCH/CRUSH
2	113-568H	MARKER TRANSPORT MOUNT
2	113-677H	20 BM MARKER TRANSPORT CARRIER
8	800-035C	CABLE TIE 28 LONG
4	802-335C	HHCS 5/8-11X6 1/2 GR5
20	803-020C	NUT HEX 1/2-13 PLT
8	803-021C	NUT HEX 5/8-11 PLT
4	803-036C	NUT HEX JAM 1/2-13 PLT
20	804-015C	WASHER LOCK SPRING 1/2 PLT
8	804-017C	WASHER FLAT 1/2 USS PLT
8	804-021C	WASHER FLAT 5/8 SAE PLT
8	804-022C	WASHER LOCK SPRING 5/8 PLT

113-694A MARKER, 3PT 20-P DUAL (cont'd)

Your kit includes:

Qty.	Part No.	Part Description
4	806-005C	U-BOLT 1/2-13 X 2 X 3 GR 5
4	806-053C	U-BOLT 5/8-11 X 7 1/32 X 6 1/2
2	806-122C	U-BOLT 1/2-13 X 3 1/32 X 6
4	806-159C	U-BOLT 1/2-13 X 5 1/32 X 4 1/2
2	810-058C	VALVE 3/8 NEEDLE
2	811-044C	AD 3/8MNPT
4	811-281C	EL 3/8FNPT 9/16MORB