

## Installation Instructions



## 3-Point Precision Seeding System Marker Option

Used with:

- 2410P and 2420P



*When you see this symbol, the subsequent instructions and warnings are serious - follow without exception. Your life and the lives of others depend on it!*

## General Information

These instructions explain how to install the Marker Option on the 24 foot 3-point Precision Seeding Systems.

The markers fold and unfold hydraulically for field operation. The marker disks leave a line for the drill operator to follow on the next field pass. Markers are mounted on the drill frame and require two hydraulic remote valves on the tractor. A sequence valve is available so markers can be operated on one hydraulic circuit.

These instructions apply to:

113-729A    24P Dual Marker Package

## Manual Update

Refer to the 3-Point Precision Seeding System operator's manual for detailed information on safely operating, adjusting, troubleshooting and maintaining the Marker Option. Refer to the parts manual for part identification.

118-769M	2410P and 2420P Operator's Manual
118-769P	2410P and 2420P Parts Manual

## Before You Start

Page 7 is a detailed listing of parts included in the Marker Option package. Use this list to inventory parts received.

## Assembly Instructions

### Marker Assemble

Refer to Figure 1.

1. Lower drill into field position. Allow 13 feet on each end of a 24-foot drill.
2. Mount first marker section (1) on drill 7 x 5 inch frame tube (2). Mount marker at the end of the drill using dimension "A" as a starting point.
3. Secure marker section with 5/8 inch u-bolts (3), lock washers, washers and nuts (4), and 1/2 inch u-bolts (5), lock washers and nuts (6).

NOTE: On the 24-foot drill with 7 1/2" inch row spacing, the last two openers are bolted to the marker mount using 5/8 x 6 1/2 inch straight bolts (7).

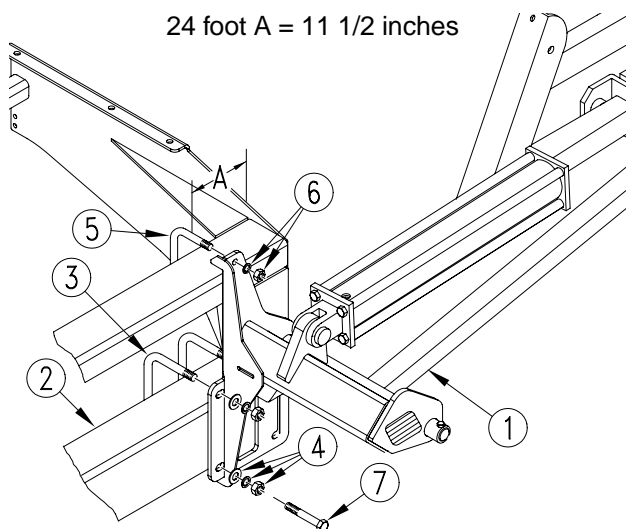

**Figure 1**  
**First Marker Section Assembly**

18413

## 2 | Marker Option

Refer to Figure 2

4. Remove port plugs on cylinder and carefully unfold first marker section. Rotate hinge section (7) into a horizontal position.
5. Align holes of break-away section (8) with holes in hinge section. Bolt sections together using a 5/8-inch pivot bolt (9), lock nut (10), 3/8-by-1 3/4-inch, grade 2 shear bolt (11) and lock nut (12).

**IMPORTANT:** Be sure shear bolt is a grade 2 bolt. Failure to use a grade 2 bolt can cause marker damage.

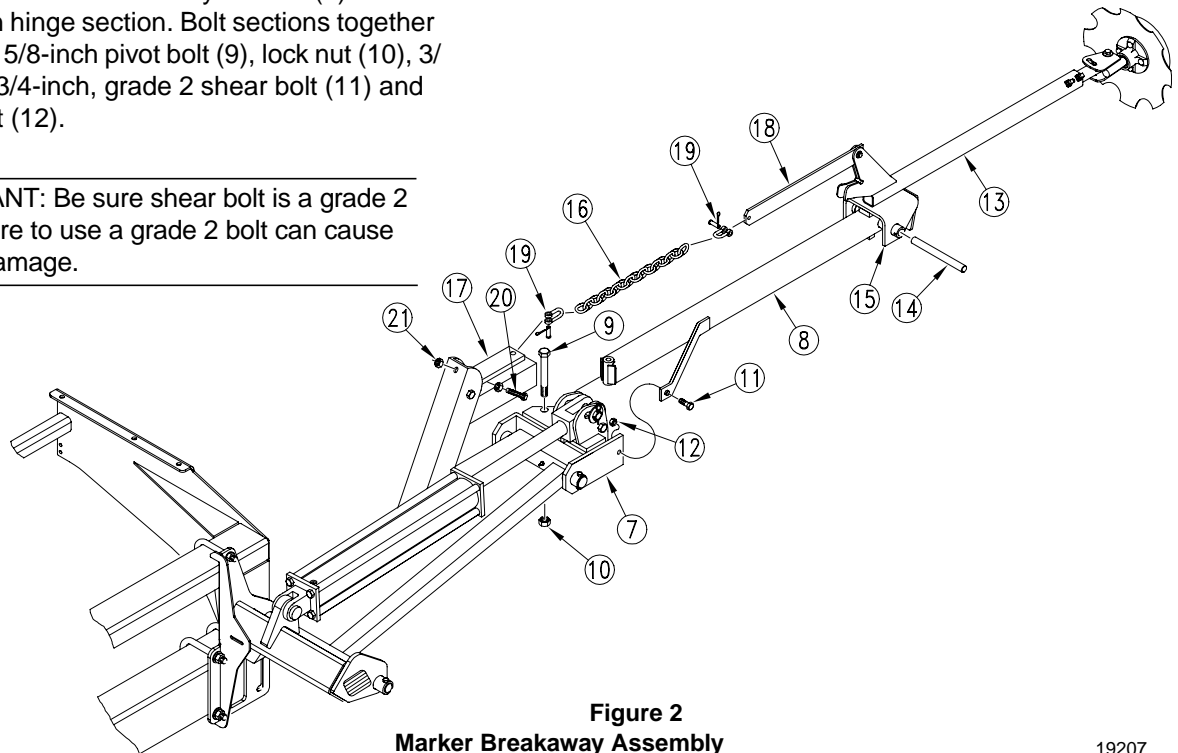

**Figure 2**  
**Marker Breakaway Assembly**

19207

6. Place third marker sections (13) over end of second section (8) and insert hinge pin through second and third section pivot (14) with the 1/4 X 2 inch bolt and lock nut.\*
7. Connect marker chain (16) to chain bar (17) and chain pivot (18) with utility clevis (19). With marker disk adjusted to seeding width and disk touching the ground, remove chain slack with utility clevis (19) nearest drill.\*
8. Assemble full-threaded 3/8 inch stop bolt (20) and lock nut (21) on lift arm extension so head of stop bolt extends as little as possible. After the marker is bled and folded, adjust stop bolt to remove slack from chain.\*
9. Repeat steps for other marker.
10. To adjust markers, refer to *Marker Adjustments* in the operator's manual.

\*NOTE: Parts are located in bolt bag.

## Carrier Assembly for 24P drill

To assemble carrier onto drill frame, refer to Figure 3.

1. Assemble transport-carrier mount (1) on drill frame. Center mount 46 1/2 inches from outside end of drill frame. Use 1/2 x 6 1/32 x 7-inch u-bolts (2), flat washers, lock washers and hex nuts (3). Slide mount forward so its leading edge is about 2 1/4 inches ahead of front edge of drill frame tube.
2. Bolt transport carrier (4) to transport-carrier mount so top surface of saddle (5) is about 29 1/4 inches above top of drill frame tube. Secure transport carrier with 1/2 x 2 x 3-inch u-bolts (6), lock washers and hex nuts (7).
3. After installing and bleeding hudraulics, transport carrier may require further adjustment. When folded, the second marker section should rest in the transport-carrier saddle..

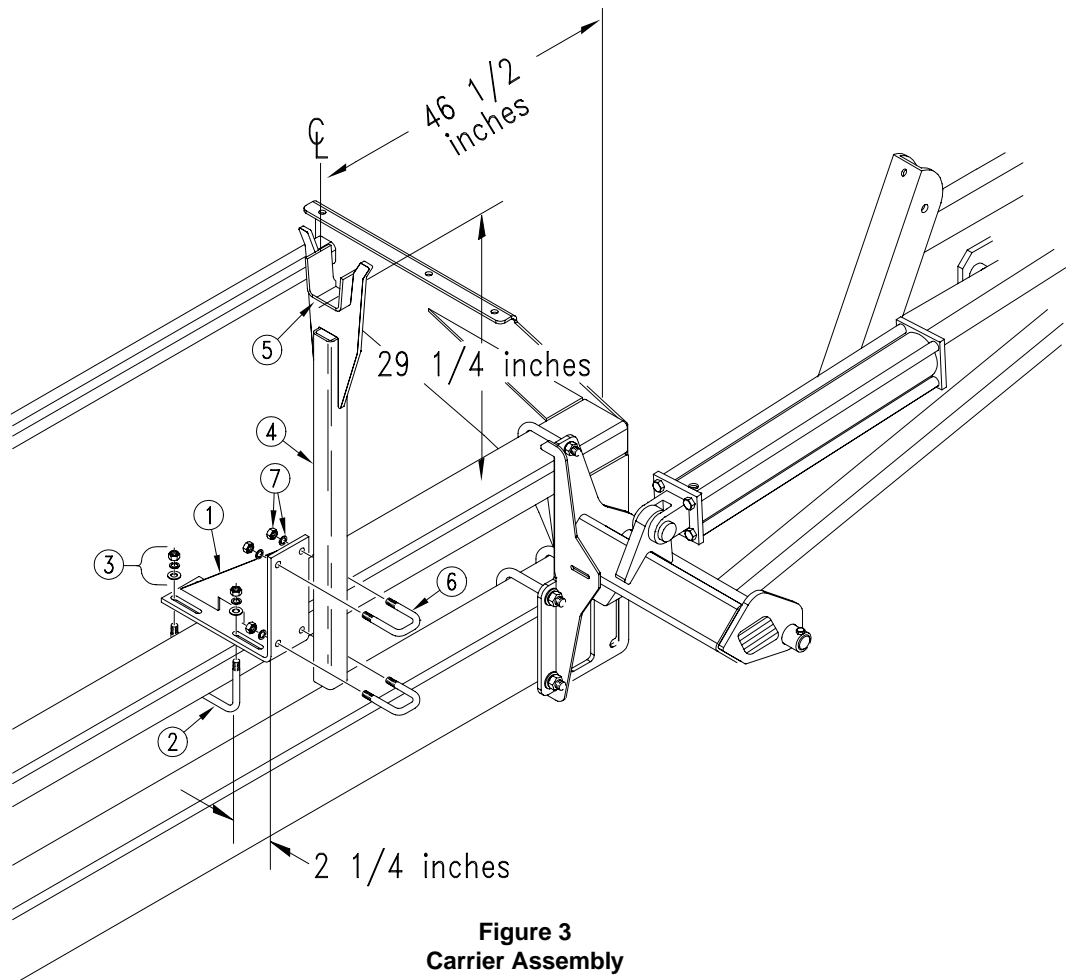

**Figure 3**  
**Carrier Assembly**

19208

- After installing and bleeding hydraulics, transport carrier may require further adjustment. When folded, the second marker section should rest in the transport-carrier saddle.

## Installing Marker Hydraulics

### Without Sequence Valve

Refer to Figure 4.

- Install elbow fittings (1) in cylinder ports.
- At rod end of each cylinder, install an adaptor (2) into elbow fitting. Install a needle valve (3) in adaptor.

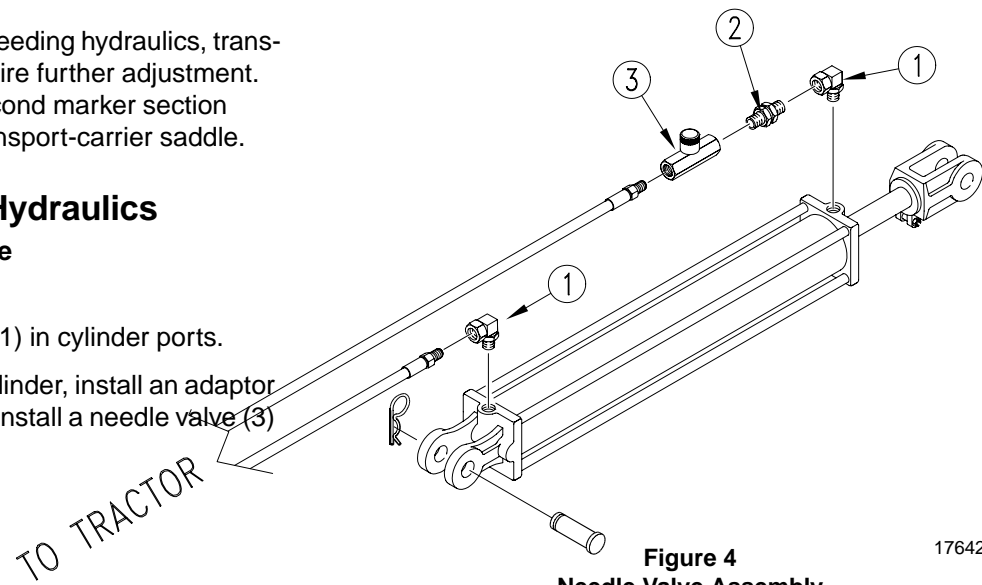

**Figure 4**  
Needle Valve Assembly

17642

- Connect hydraulic hoses to fittings and route hydraulic hoses to tractor outlets. Route hydraulic hoses through transport-carrier mount at cutout. Use black cable ties to secure hydraulic hoses to drill frame.
- Using orange cable ties, secure a plastic hose label, see Figure 5, to each pair of hydraulic hoses near tractor outlets.
- Proceed with "Bleeding Marker Hydraulics" on page 5.

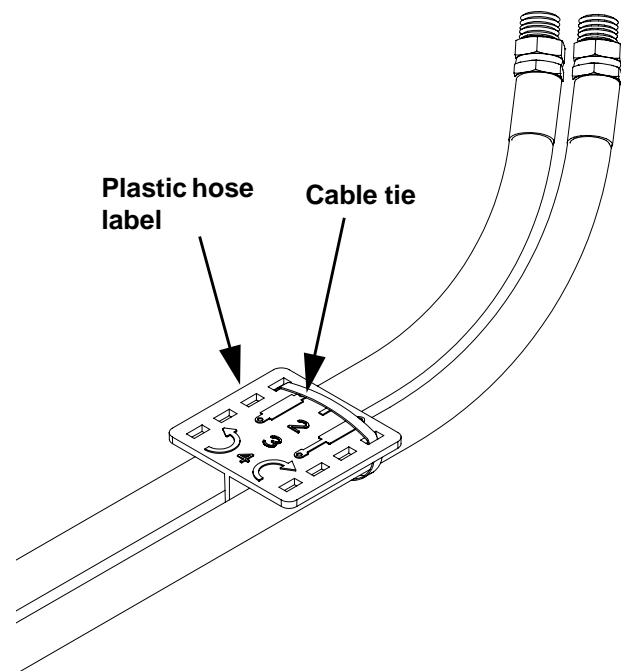

**Figure 5**  
Hose label and cable tie

17641

**With Sequence Valve**

Refer to Figure 6.

1. Mount sequence valve (1) 810-197C on drill using mounting plate (2) 113-488D. Bolt plate to inside end of left-hand-box panel (3) using one 1/2-inch hex bolt (4). The sequence valve and mounting plate can be purchased separately from your Great Plains Dealer.
2. Bolt valve (1) to mounting plate (2) with two 3/8 x 3/4-inch hex bolts and lock washers (5).
3. Install elbow fittings in cylinder ports. Discard adaptor fitting and two needle valves provided in marker kit.
4. Use hoses provided to connect valve ports to cylinders. Refer to Figure 7 for port connections. (1) 811-440C and (2) 811-169C, dealer and customer must order these separately.
5. Connect your own hydraulic hoses to ports on front of valve. Route hoses to tractor outlets.
6. Using orange cable tie, secure plastic hose label, see Figure 5, to hydraulic hoses near tractor outlets.
7. Proceed with "Bleeding Marker Hydraulics" on page 5.

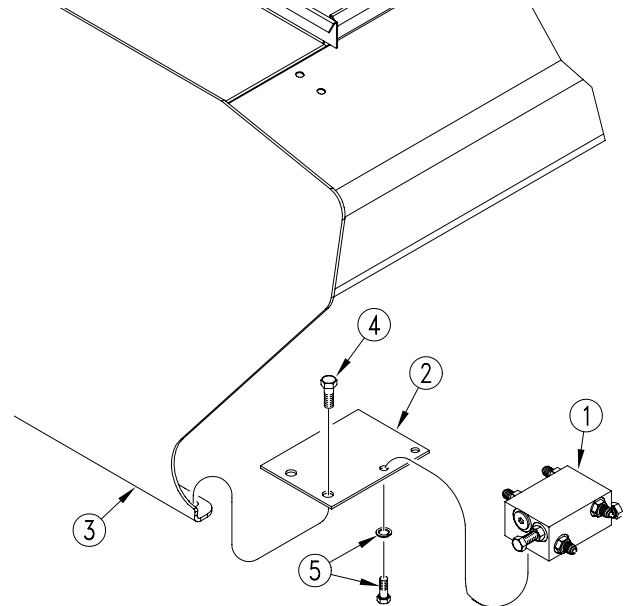

**Figure 6**  
**Sequence Valve Assembly**

18416

**Figure 7**  
**Hydraulic Hose Connection**

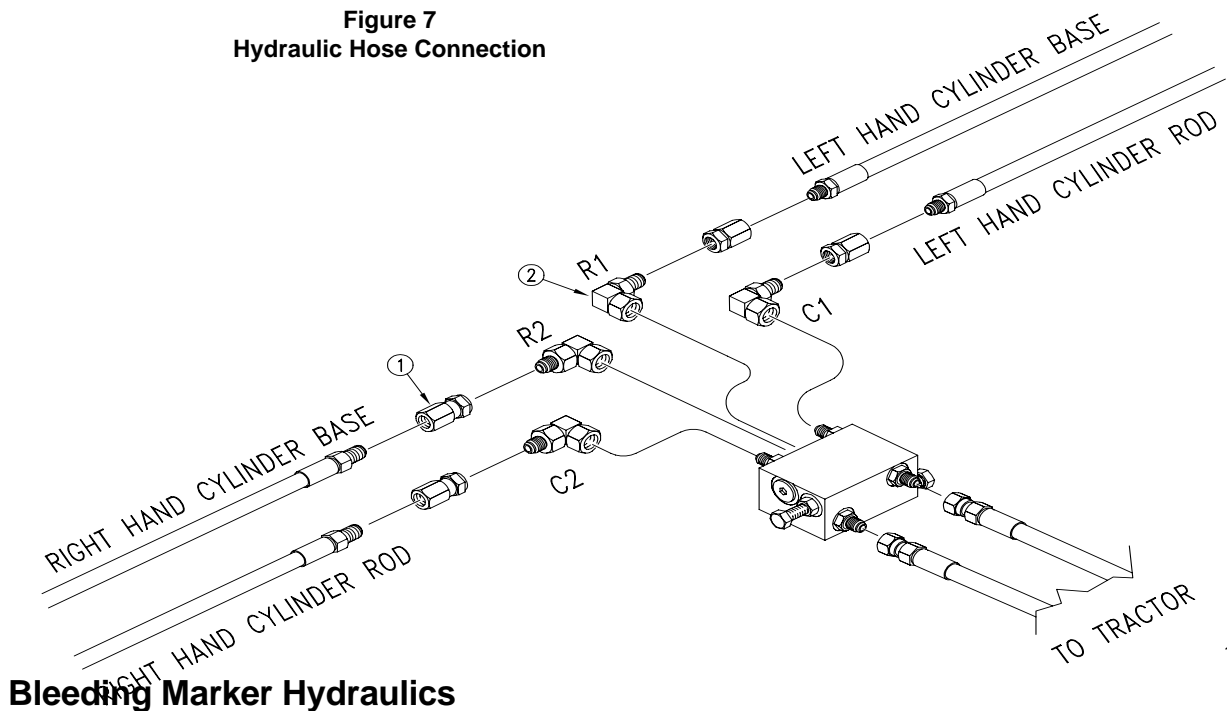

19209

**Bleeding Marker Hydraulics**

**CAUTION!**

*You may be injured if hit by a folding or unfolding marker. Markers may fall quickly and unexpectedly if the hydraulics fail. Never allow anyone near the drill when folding or unfolding the markers.*

**WARNING!**

*Escaping fluid under pressure can have sufficient pressure to penetrate the skin. Check all hydraulic lines and fittings before applying pressure. Fluid escaping from a very small hole can be almost invisible. Use paper or cardboard, not body parts, and wear heavy gloves to check for suspected leaks. If injured, seek medical assistance from a doctor that is familiar with this type of injury. Foreign fluids in the tissue must be surgically removed within a few hours or gangrene will result.*

1. Check that tractor hydraulic reservoir is full.
2. With both markers lowered into field position, loosen hydraulic-hose fittings at rod and base ends of marker cylinders. If applicable, loosen fittings on back side of sequence valve.

---

**IMPORTANT:** Never bleed an O-ring fitting. Instead, bleed a nearby pipe or JIC fitting.

---

3. With tractor idling, activate tractor hydraulic valve until oil seeps out around a loosened fitting. Tighten that fitting.

---

**IMPORTANT:** JIC fittings do not require high torque. JIC and O-ring fittings do not require sealant. Always use liquid pipe sealant when adding or replacing pipe-thread fittings. To avoid cracking hydraulic fittings from over tightening, do not use plastic sealant tape.

---

4. Reactivate tractor hydraulic valve until oil seeps out around another loosened fitting. Tighten that fitting. Repeat process until all loosened fitting have been bled and tightened.
5. Adjust marker folding to a safe speed. Refer to "Marker Adjustments" in the operator's manual.

**113-729A MARKER, 3PT 24P DUAL**

Your kit includes:

Qty.	Part No.	Part Description
<b>1</b>	<b>113-740K</b>	<b>MARKER BUNDLE 24-P 3PT DUAL</b>
1	113-180H	LH FIRST SECTION
1	113-181H	LIFT LUG CHANNEL LH
1	113-183H	30' FF MARKER 3RD SECTION
1	113-188H	RH FIRST SECTION
1	113-189H	LIFT LUG CHANNEL RH
2	113-195H	3 SECTION MARKER BREAKAWAY
1	113-196H	24' FF MARKER 3RD SECTION
2	113-200H	CHAIN BAR WELDMENT
2	113-248D	PIN 1 OD X 4.34 USABLE.
2	113-311D	HINGE PIN
2	113-312D	FIRST PIVOT SHAFT
2	113-313D	SECOND PIVOT SHAFT
2	113-323D	CHAIN BAR
2	113-324D	CYLINDER STOP
4	113-325D	STOP BUSHING
1	113-352D	MARKER TUBE 30 LONG
1	113-354D	13' MARKER TUBE 46 1/2 LONG
2	113-560H	MARKER CARRIER
2	113-563S	MARKER DISC & HUB ASSEMBLY
2	113-568H	MARKER TRANSPORT MOUNT
1	113-689H	MARKER MOUNT LH
1	113-690H	MARKER MOUNT RH
6	800-001C	GREASE ZERK STRAIGHT 1/4-28
4	801-054C	SCREW SET SQ HD 1/2-13X1 GR5
2	802-022C	HHCS 3/8-16X1 1/2 GR5
4	802-039C	HHCS 1/2-13X3 GR5
6	802-115C	HHCS 5/16-18X2 GR5
2	802-168C	HHCS 5-16-18X2 GR5
2	802-249C	HHCS 1/2-13X4 1/2 GR5 SPTHD
2	802-254C	HHCS 5/8-11X5 1/2 GR5
2	802-261C	HHCS 3/8-16X2 GR5 FTHD
2	802-266C	HHCS 3/8-16X2 GR2
6	803-011C	NUT LOCK 5/16-18 PLT
10	803-013C	NUT LOCK 3/8-16 PLT
2	803-019C	NUT LOCK 1/2-13 PLT
12	803-020C	NUT HEX 1/2-13 PLT
2	803-024C	NUT LOCK 5/8-11 PLT
4	803-036C	NUT HEX JAM 1/2-13 PLT
4	804-011C	WASHER FLAT 3/8 USS PLT
12	804-015C	WASHER LOCK SPRING 1/2 PLT
8	804-017C	WASHER FLAT 1/2 USS PLT
4	804-029C	WASHER FLAT 1 SAE
4	805-058C	PIN COTTER 3/16 X 2
2	806-005C	U-BOLT 1/2-13 X 2 X 3 GR 5
1	810-118C	CYL 2.5X20X1.12 ROD (TIE) 1
2	818-229C	DECAL AMBER REFLECTOR
4	818-682C	DECAL WARNING PINCH/CRUSH MRKR
6	803-011C	NUT LOCK 5/16-18
4	803-021C	NUT HEX 5/8-11 PLT

## 8 Marker Option

**113-729A MARKER, 3PT 24P DUAL**

Your kit includes:

Qty.	Part No.	Part Description
<b>1</b>	<b>113-741K</b>	<b>MARKER HRDWR 24P DUAL</b>
2	113-328D	24' MARKER CHAIN
1	113-351D	MARKER TUBE 42 LG
12	800-082C	CABLE TIE .31X21.5 6 DIA 120
2	800-300C	CABLE TIE 2 DIA MIN - ORG
4	802-335C	HHCS 5/8-11X6 1/2 GR5
12	803-020C	NUT HEX 1/2-13 PLT
8	803-021C	NUT HEX 5/8-11 PLT
12	804-015C	WASHER LOCK SPRING 1/2 PLT
8	804-017C	WASHER FLAT 1/2 USS PLT
8	804-021C	WASHER FLAT 5/8 SAE PLT
8	804-022C	WASHER LOCK SPRING 5/8 PLT
4	806-053C	U-BLOT 5/8-11X7 1/32X6
4	806-159C	U-BOLT 1/2-13 X 5 1/32 X 4
2	810-058C	VAVLE 3/8 NEEDLE
2	811-044C	AD 3/8MNPT
2	811-281C	EL 3/8FNPT 9/16MORB
2	817-348C	PLASTIC HOSE LABEL
4	890-018C	5/16X1 1/4 UTILITY CLEVIS
1	113-742M	MANUAL MARKERS 24-P 3PT
<b>1</b>	<b>113-624V</b>	<b>24' 3PT DUAL MARKER HOSE BUNDLE</b>
2	811-129C	HH1/4R1 234 3/8MNPT 1/2MNPT
2	811-297C	SP HH1/4R1 212 3/8MNPT-W/AD