



Great Plains

Manufacturing, Inc.

Seed Rate and Fertilizer Application Charts for FCP1000

The following pages are to assist in the proper setting of seeding and fertilizer application rates for the FCP1000. The rates indicated in the charts are approximate values. To assure the most accurate seeding rate it is recommended that the drill be calibrated for the desired seed at the time of planting.

Setting the Seeding Rate

Calibrating the seeding rate requires four steps:

- set correct drive type,
- setting seed-rate handle,
- positioning seed-cup doors, and
- checking seeding rate.

Refer to the seed-rate charts starting on page 4. These charts list proper sprocket sizes and seed-rate-handle settings for various seeds and seeding rates.

The seed-rate charts are based on cleaned, untreated seed of average size and test weight. The charts are based on 13.0/55-16 12 PR AW tires. Many factors will affect seeding rates including foreign material, seed treatment, seed size, field conditions, tire pressure and test weight. You likely will need to make minor adjustments. Set and check the seeding rate using procedures below, then readjust rate as necessary.

Changing Drive Sprockets

For correct drive type, refer to seed-rate charts starting on page 4. The charts lists drive types as 1, 2, 3 or 4. Refer to the following table for correct-sized sprocket for each drive type.

Drive Type	Sprocket	Speed
Type 1	72-tooth	Slowest
Type 2	34 tooth	Two Times Faster Than Type 1
Type 3	23-tooth	Three Times Faster Than Type 1
Type 4	14-tooth	Five Times Faster Than Type 1

To change drive types, remove the chain guard (1) by loosening wing nuts (2). See Figure 3-1.

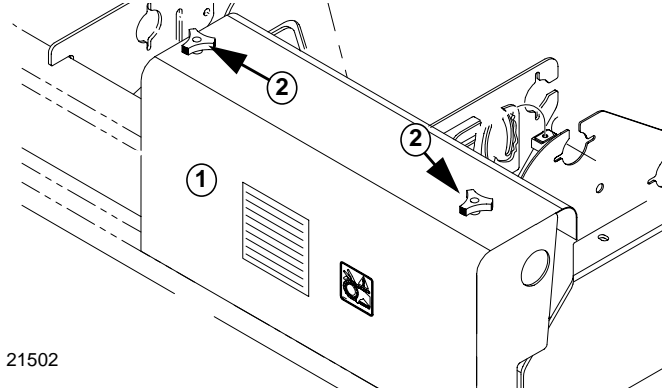

21502

Figure 3-1
Chain Guard

Loosen idler (1) and remove drive chain shown in Figure 3-2. Remove lynch pin from shaft (2) and re-arrange sprockets on shaft.

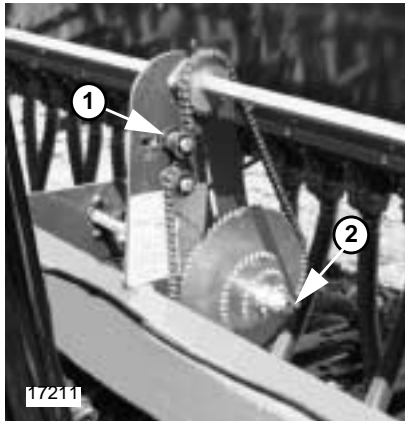

17211

Figure 3-2
Drive Sprockets

NOTE: Be sure chain is installed with the chain connector link retainer towards the centerline and the clip opening (split end) faces the opposite way of the chain travel.

Setting Seed-Rate Handle

Position seed-rate handle shown in Figure 3-3 to setting indicated on seed-rate charts.

To adjust, loosen wing nut under handle. Slide handle until indicator is just past the correct setting, then move the handle back until indicator lines up with correct setting.

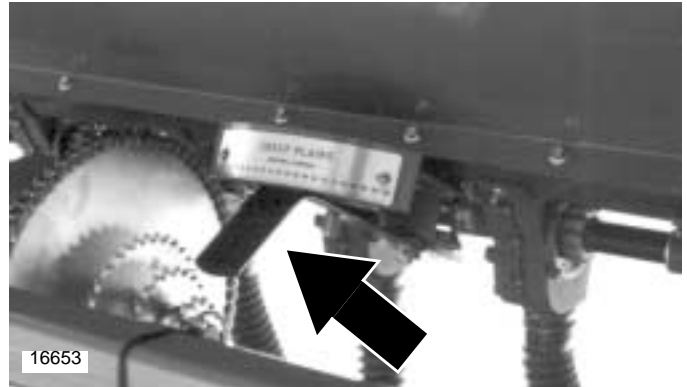

Figure 3-3
Seed-Rate Handle

Positioning Seed-Cup Doors

For wheat and other small seeds, move seed-cup-door handles to the highest position. For soybeans and other large seeds, lower handles to second position. If excessive seed cracking occurs, lower handles to third position. For seed-cup clean out, move handles to the fourth, wide-open position. Make sure all handles are in the same position before drilling.

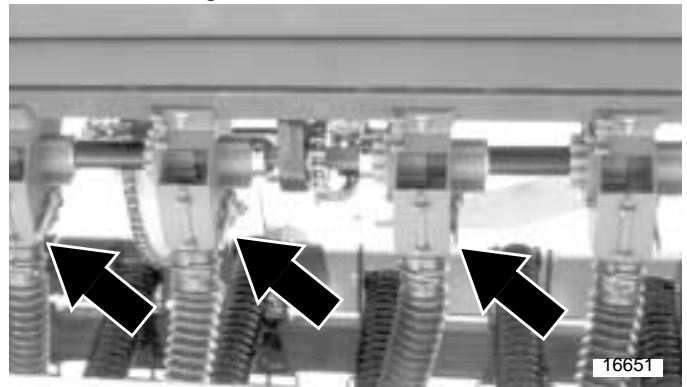

Figure 3-4
Seed-Cup-Door Handle

Checking Seeding Rate



WARNING!

You may be severely injured or killed by being crushed by the falling implement. Always have transport locks in place and frame sufficiently blocked up when working on the implement.

1. Raise drill with tractor hydraulics so gauge wheels are off ground. Rotate drive (far right) gauge wheel to see that metering system is working properly and free from foreign material.
2. Check that implement tires are 13.0/55-16 12 PR AW and properly inflated. Refer to *Tire Inflation Chart*, “**Appendix**,” in the operator’s manual.
3. Record weight of an empty container large enough to hold seed metered for one hectare (acre).
4. Place several kilos (pounds) of seed over three seed cups on an outside end of the seed box. Pull seed tubes off of these three openers.
5. Turn crank on contact-wheel shaft on right-hand side of drill several times to fill seed cups. Turn crank until seed drops to ground from each seed cup.
6. Place a container under these three tubes to gather metered seed.
7. Turn crank on contact-wheel shaft clockwise 32 revolutions for 1/100 hectare seeding rate (13 rotations for a 1/100 acre seeding rate). While turning, check that the seed cups have plenty of seed coming into them.

NOTE: If implement is not equipped with a calibration crank, turn drive gauge wheel 319 rotations for a one-hectare seeding rate or 127 rotation for a one-acre seeding rate.

8. Weigh metered seed. Subtract initial container weight. Multiply weight by
 - 633.33 for 158 mm (6.2 inch) row spacing or to determine total kilograms per hectare (pounds per acre) seeded. If this figure is different than desired, adjust seed-rate handle accordingly.

NOTE: You may want to repeat the calibration procedure if your results vary greatly from the seed-rate chart.

9. When drilling, check seeding rate by noting acres drilled, amount of seed added to drill and seed level in seed box. If you are seeding more or less than desired, adjust rate slightly to compensate for field conditions.

Seed Rate Charts

White Rows, Metric
Shaded Rows, English Units

Seed-Rate Handle	0	5	10	15	20	25	30	35	40	45	50	55	60	65	70	75	80	85	90	95	100	
	Seeding Rate, Pounds per Acre/Kilograms Per Hectare																					
Alfalfa or Rape	6.2 in.	2.2	5.5	8.3	12.0	15.4	19.1	22.80	27.2	31.5	36.7	41.0	44.8	49.6	54.2	59.0	63.2	68.7	73.9	79.30	81.6	84.0
Drive Type 1	157.9mm	2.6	6.4	9.6	13.9	17.9	22.2	26.5	31.6	36.6	42.6	47.6	52.0	57.6	63.0	68.5	73.4	79.8	85.8	92.1	94.8	97.6

(Based on 60#/bushel; .772 kb/har)

Barley	6.2 in.	1.9	4.5	7.6	10.7	14.4	18.1	22.2	26.1	30.1	34.5	38.9	43.3	47.8	52.8	57.1	61.7	65.5	69.1	72.6	73.1	73.7
Drive Type 1	157.9mm	2.2	5.2	8.8	12.4	16.7	21.0	25.8	30.3	35.0	40.1	45.2	50.3	55.5	61.3	66.3	71.7	76.1	80.3	84.3	84.9	85.6

(Based on 51#/bushel; .656 kb/har)

Barley	6.2 in.	3.5	8.7	15.9	21.6	29.8	37.0	45.1	53.7	61.8	71.0	76.4	87.0	95.8	104.1	113.5	122.7	132.8	142.4	151.6	154.0	156.4
Drive Type 2	157.9mm	4.1	10.1	18.5	25.1	34.6	43.0	52.4	62.4	71.8	82.5	88.8	101.1	111.3	120.9	131.9	142.5	154.3	165.4	176.1	178.9	181.7

(Based on 51#/bushel; .656 kb/har)

Barley	6.2 in.	8.5	21.2	38.8	52.7	72.9	90.4	110.3	131.3	151.1	173.7	194.1	212.7	234.4	254.6	277.7	300.0	324.7	348.3	370.6	376.5	382.4
Drive Type 3	157.9mm	9.9	24.6	45.1	61.2	84.7	105.0	128.1	152.5	175.5	201.8	225.5	247.1	272.3	295.8	322.6	348.5	377.2	404.6	430.5	437.4	444.2

(Based on 51#/bushel; .656 kb/har)

Buck-wheat	6.2 in.	0.0	11.3	21.0	29.4	41.9	52.2	65.0	77.9	92.4	108.8	123.1	135.7	150.4	165.4	179.5	195.4	209.3	224.0	252.6	241.9	244.5
Drive Type 4	157.9mm	0.0	13.1	24.4	34.2	48.7	60.6	75.5	90.5	107.3	126.4	143.0	157.6	174.7	192.1	208.5	227.0	243.1	260.2	293.4	281.0	284.0

(Based on 48#/bushel; .618 kb/har)

Flax or Sudan	6.2 in.	0.0	3.7	8.2	11.7	16.1	20.1	24.1	28.3	32.8	37.0	41.8	45.7	49.9	54.4	59.1	64.7	69.80	75.7	81.9	83.2	84.9
Drive Type 1	157.9mm	0.0	4.3	9.5	13.6	18.7	23.4	28.0	32.9	38.1	43.0	48.6	53.1	58.0	63.2	68.7	75.2	81.1	87.9	95.1	96.7	98.6

(Based on 55#/bushel; .708 kb/har)

Millet	6.2 in.	1.4	4.7	8.2	11.7	15.7	19.5	23.4	27.2	31.5	35.7	39.8	44.0	48.5	52.4	57.0	61.7	66.00	70.8	75.8	77.0	78.1
Drive Type 1	157.9mm	1.6	5.5	9.5	13.6	18.2	22.7	27.2	31.6	36.6	41.5	46.2	51.1	56.3	60.9	66.2	71.7	76.7	82.2	88.1	89.5	90.7

(Based on 60#/bushel; .722 kb/har)

Milo	6.2 in.	0.0	4.7	8.8	13.0	17.7	22.5	27.80	33.5	39.0	44.8	51.5	56.7	62.8	68.8	74.7	80.8	86.6	91.7	97.70	100.3	102.1
Drive Type 1	157.9mm	0.0	5.5	10.2	15.1	20.6	26.1	32.3	38.9	45.3	52.0	59.8	65.9	73.0	79.9	86.8	93.9	100.6	106.5	113.5	116.5	118.6

(Based on 64#/bushel; .824 kb/har)

White Rows, Metric
Shaded Rows, English Units

Seed-Rate Handle	0	5	10	15	20	25	30	35	40	45	50	55	60	65	70	75	80	85	90	95	100
------------------	---	---	----	----	----	----	----	----	----	----	----	----	----	----	----	----	----	----	----	----	-----

Row Space Seeding Rate, Pounds per Acre/Kilograms Per Hectare

Oats	6.2 in.	0.0	5.2	12.1	17.3	24.0	31.5	38.7	46.8	54.8	63.2	72.2	79.7	88.0	96.1	104.5	112.2	121.2	129.6	138.6	140.3	139.7
	157.9mm	0.0	6.0	14.1	20.1	27.9	36.6	45.0	54.4	63.7	73.4	83.9	92.6	102.2	111.6	121.4	130.3	140.8	150.6	161.0	163.0	162.3
Drive Type 3																						

(Based on 37#/bushel; .476 kb/har)

Peas	6.2 in.	0.0	9.5	18.9	34.1	51.9	68.7	83.9	101.9	118.9	137.4	154.3	169.4	186.2	201.5	218.2	235.4	250.8	266.1	281.4	282.9	284.1
	157.9mm	0.0	11.0	22.0	39.6	60.3	79.8	97.5	118.4	138.1	159.6	179.3	196.8	216.3	234.1	253.5	273.5	291.4	309.1	326.9	328.6	330.0
Drive Type 3																						

(Based on 61#/bushel; .785 kb/har)

Pinto Beans	6.2 in.	0.0	0.0	8.5	12.9	17.4	23.6	29.60	35.3	41.2	47.1	53.0	58.2	63.7	68.8	74.4	80.8	85.4	90.7	96.60	96.4	96.3
	157.9mm	0.0	0.0	9.9	15.0	20.2	27.4	34.4	41.0	47.9	54.7	61.6	67.6	74.0	79.9	86.4	93.9	99.2	105.4	112.2	112.0	111.9
Drive Type 1																						

(Based on 61#/bushel; .785 kb/har)

Rice- Long Grain	6.2 in.	0.0	0.0	13.2	21.6	31.6	41.9	52.7	61.2	70.7	80.8	89.8	98.1	106.5	115.5	125.3	134.7	144.3	153.3	161.0	167.1	172.9
	157.9mm	0.0	0.0	15.3	25.1	36.7	48.7	61.2	71.1	82.1	93.9	104.3	114.0	123.7	134.2	145.6	156.5	167.6	178.1	187.0	194.1	200.9
Drive Type 3																						

(Based on 47#/bushel; .605 kb/har)

Rice- Long Grain	6.2 in.	0.0	0.0	21.5	35.3	51.5	68.2	85.9	99.8	115.3	131.8	146.3	160.0	173.7	188.3	204.3	219.6	235.3	249.9	262.5	272.5	281.9
	157.9mm	0.0	0.0	25.0	41.0	59.8	79.2	99.8	115.9	133.9	153.1	170.0	185.9	201.8	218.7	237.3	255.1	273.3	290.3	304.9	316.6	327.5
Drive Type 4																						

(Based on 47#/bushel; .605 kb/har)

Rice- Short Grain	6.2 in.	2.9	11.0	18.0	28.3	38.3	45.6	55.5	63.5	73.3	83.7	95.6	106.8	117.2	127.9	138.6	147.9	156.5	165.1	174.1	174.1	174.1
	157.9mm	3.4	12.8	20.9	32.9	44.5	53.0	64.5	73.8	85.2	97.2	111.1	124.1	136.2	148.6	161.0	171.8	181.8	191.8	202.3	202.3	202.3
Drive Type 3																						

(Based on 43#/bushel; .553 kb/har)

Rice- Short Grain	6.2 in.	4.7	17.9	29.4	46.1	62.5	74.4	90.5	103.5	119.5	136.5	155.9	174.1	191.1	208.5	225.9	241.2	255.1	269.2	283.9	283.8	283.9
	157.9mm	5.5	20.8	34.2	53.6	72.6	86.4	105.1	120.2	138.8	158.6	181.1	202.3	222.0	242.2	262.4	280.2	296.4	312.7	329.8	329.7	329.8
Drive Type 4																						

(Based on 43#/bushel; .553 kb/har)

Rye	6.2 in.	0.0	2.8	7.8	12.6	18.5	24.0	28.0	34.6	40.7	47.0	52.0	58.0	62.9	68.3	73.8	80.5	86.50	93.5	101.0	101.7	102.1
	157.9mm	0.0	3.3	9.1	14.6	21.5	27.9	32.5	40.2	47.3	54.6	60.4	67.4	73.1	79.3	85.7	93.5	100.5	108.6	117.3	118.1	118.6
Drive Type 1																						

(Based on 57#/bushel; .553 kb/har)

White Rows, Metric
Shaded Rows, English Units

Seed-Rate Handle	0	5	10	15	20	25	30	35	40	45	50	55	60	65	70	75	80	85	90	95	100
------------------	---	---	----	----	----	----	----	----	----	----	----	----	----	----	----	----	----	----	----	----	-----

Row Space Seeding Rate, Pounds per Acre/Kilograms Per Hectare

Soy-beans Drive Type 2	6.2 in.	0.0	5.8	16.0	26.9	39.6	47.5	58.9	69.3	80.4	91.8	101.6	113.9	125.3	136.1	146.8	158.2	167.4	178.6	190.1	191.1	191.7
	157.9mm	0.0	6.7	18.6	31.2	46.0	55.2	68.4	80.5	93.4	106.6	118.0	132.3	145.6	158.1	170.5	183.8	194.5	207.5	220.8	222.0	222.7

(Based on 58#/bushel; .747 kb/har)

Soy-beans Drive Type 3	6.2 in.	0.0	11.5	22.5	40.4	59.5	70.7	88.9	101.0	116.3	131.3	148.1	164.0	180.7	196.3	213.6	227.5	248.2	265.3	284.0	283.8	284.3
	157.9mm	0.0	6.7	18.6	31.2	46.0	55.2	68.4	80.5	93.4	106.6	118.0	132.3	145.6	158.1	170.5	183.8	194.5	207.5	220.8	222.0	222.7

(Based on 58#/bushel; .747 kb/har)

Soy-beans Drive Type 4	6.2 in.	0.0	19.0	37.0	66.0	97.0	115.0	145.0	165.0	190.0	214.0	241.0	267.0	295.0	320.0	348.0	371.0	405.0	433.0	463.0	463.0	464.0
	157.9mm	0.0	22.1	43.0	76.7	112.7	133.6	168.4	191.7	220.7	248.6	280.0	310.2	342.7	371.7	404.3	431.0	470.5	503.0	537.9	537.9	539.0

(Based on 58#/bushel; .747 kb/har)

Sunflow-ers Drive Type 1	6.2 in.	0.0	0.0	2.0	4.2	6.1	8.3	10.7	12.9	15.4	17.8	20.2	22.5	24.9	27.3	29.7	39.1	34.10	36.0	38.8	39.4	40.7
	157.9mm	0.0	0.0	2.3	4.9	7.1	9.6	12.4	15.0	17.9	20.7	23.5	26.1	28.9	31.7	34.5	45.4	39.6	41.8	45.1	45.8	47.3

(Based on 28#/bushel; .360 kb/har)

Wheat Drive Type 2	6.2 in.	0.0	12.5	21.9	30.4	39.5	49.7	57.4	69.9	80.4	91.4	104.7	115.1	127.4	140.3	152.2	164.2	177.1	189.9	203.0	205.7	205.9
	157.9mm	0.0	14.5	25.4	35.3	45.9	57.7	66.7	81.2	93.4	106.2	121.6	133.7	148.0	163.0	176.8	190.8	205.7	220.6	235.8	239.0	239.2

(Based on 64#/bushel; .824 kb/har)

Wheat Drive Type 3	6.2 in.	0.0	15.9	30.6	44.7	59.5	74.2	87.5	103.6	120.1	136.5	153.3	168.0	185.6	202.4	220.2	239.9	255.8	273.6	289.8	296.7	298.8
	157.9mm	0.0	18.5	35.5	51.9	69.1	86.2	101.6	120.4	139.5	158.6	178.1	195.2	215.6	235.1	255.8	278.7	297.2	317.8	336.7	344.7	347.1

(Based on 64#/bushel; .824 kb/har)

Wheat Grass Drive Type 1	6.2 in.	0.0	0.9	2.1	3.0	4.2	5.1	6.0	7.4	8.4	9.6	10.8	11.9	13.1	14.2	15.4	16.8	17.9	19.3	18.50	20.8	21.1
	157.9mm	0.0	1.0	2.4	3.5	4.9	5.9	7.0	8.6	9.8	11.2	12.5	13.8	15.2	16.5	17.9	19.5	20.8	22.4	21.5	24.2	24.5

(Based on 23#/bushel; .296 kb/har)

Fertilizer Rate Calibration

The fertilizer rates are controlled by a sprocket speed change selection and by a slide gate which controls the meter opening size. The charts shown are calculated with the openings at 100% open. Any adjustments to the opening at less than 100% open will have to be calibrated for the correct rate. (See calibration instructions below.)

Fertilizer application rates will vary with fertilizer type, density and particle size. Relative humidity and field conditions can also affect application rates. The charts on page 8 are based on fertilizer with average particle size and a density of 1.04 kilograms per litre (65 pounds per cubic foot). Initially set rate according to charts, then calibrate drill to your material as described on this page.

1. Refer to fertilizer rate charts on page 8 for correct sprocket sizes for your drill and desired meter rate.

IMPORTANT: The rate charts are for granular fertilizer with a density of 1.04 kilograms per litre (65 pounds per cubic foot). If you are applying fertilizer with a different density, use density conversion chart on page 9.

2. To switch between high and low range, loosen and slide idler sprocket (1) out of chain shown in Figure 3-1. Remove lynch pin from end of shaft and install correct sprocket.
 - For high range, install 16-tooth sprocket and shorten chain by removing 16-pitch strand.
 - For low range, install 44-tooth sprocket and lengthen chain by reinstalling 16-pitch strand.
 - For extra-high range, install 12-tooth sprocket and shorten chain by removing 16-pitch strand.
 - For special high range, install 12-tooth sprocket and shorten chain by removing 16-pitch strand.

NOTE: Special High Range Fertilizer Sprocket

In order to run special high rate fertilizer it will be necessary to change the final drive sprocket from a 12 tooth to a 19 tooth sprocket. Refer to Figure 3-2.

- a. Loosen the idler sprocket on the fertilizer final drive chain.
- b. Remove the lynch pin and remove the 12 tooth sprocket.
- c. Install the 19 tooth sprocket and replace the lynch pin.
- d. Tighten the idler sprocket on the fertilizer final drive chain

Move idler sprocket back into place so chain has 6 mm (1/4-inch) slack.

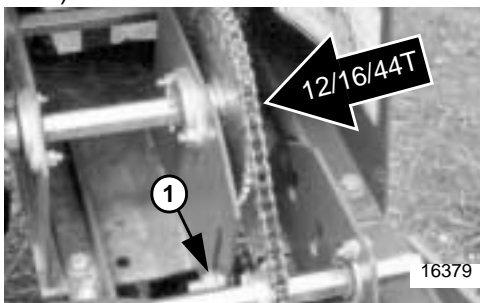

Figure 3-1
Hi/Low Range Sprocket

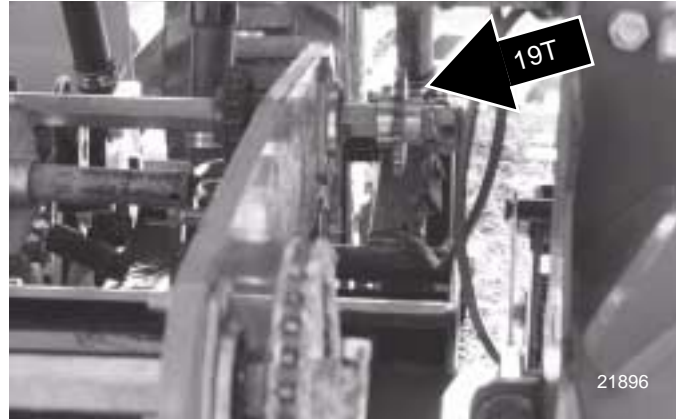

Figure 3-2
Special High Range Sprocket .

3. To change driver/driven ratio, refer to Figure 3-3.. Loosen and slide idler sprockets out of chain. Remove lynch pins from shafts. Place correct sprockets on shafts. Store sprockets not used on ends of shafts. Reinstall chain and slide idlers back into place so chain has 6 mm (1/4-inch) slack.

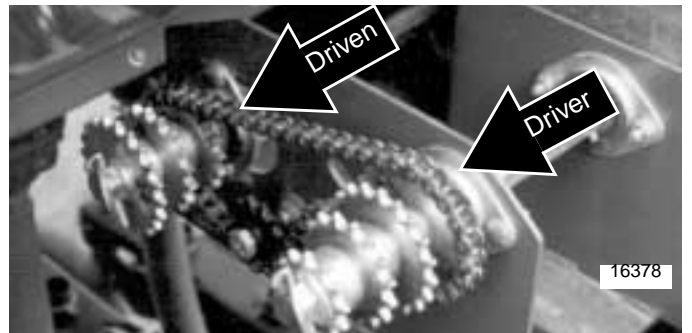

Figure 3-3
Driver/Driven Sprockets

4. Raise drill with tractor hydraulics so the contact wheels are not touching the gauge wheels. Rotate drive gauge wheel to see that metering system is working properly and free from foreign material.
5. Check that your gauge-wheel tires are 13.0/55-16 12 PR AW and properly inflated. Refer to *Tire Inflation Chart*, "Appendix," in the Operator's manual.
6. Place several kilos (pounds) of fertilizer over three fertilizer feed cups on outside end of drill box. Pull fertilizer tubes off of these three disk openers.
7. Weigh an empty container large enough to hold fertilizer applied to one hectare (acre).
8. Turn drive wheel until fertilizer starts to drop to ground.
9. Place container under the three tubes to gather metered fertilizer.
10. Turn drive gauge wheel 319 rotations for a one-hectare seeding rate or 127 rotations for a one-acre seeding rate. Check that feed cups have plenty of fertilizer coming into them.

11. Weigh metered material. Subtract weight of empty container. Divide by three. Multiply by number of openers on your drill to determine total kilograms (pounds) metered per hectare (acre). If this figure is different than desired, reset sprockets accordingly.

NOTE: You may want to repeat calibration procedure if your results vary greatly from fertilizer rate chart.

12. When drilling, check metering rate by noting hectares (acres) drilled, amount of fertilizer added to drill and level of material in drill box. If you are applying more or less fertilizer than desired, adjust metering rate slightly to compensate for field conditions.

Fertilizer Meter Rate Charts

Based on 1.04 kilograms-per-litre (65 pounds-per-cubic-foot) density

For 157.9 mm (6.2 in.) Row Spacing

Metering Rate		Sprockets			Metering Rate		Sprockets		
kg/har	lb/acre	Range	Driver	Driven	kg/har	lb/acre	Range	Driver	Driven
48.8	42	Low	12T	21T	141.7	122	High	12T	20T
51.1	44	Low	12T	20T	142.9	123	Low	20T	12T
54.6	47	Low	12T	19T	148.7	128	High	12T	19T
56.9	49	Low	12T	18T	151.0	130	Low	21T	12T
60.4	52	Low	12T	17T	156.8	135	High	12T	18T
63.9	55	Low	12T	16T	166.1	143	High	12T	17T
69.7	60	Low	17T	21T	190.5	164	High	17T	21T
73.2	63	Low	17T	20T	199.8	172	High	17T	20T
76.7	66	Low	17T	19T	210.3	181	High	17T	19T
81.3	70	Low	20T	21T	224.2	193	High	20T	21T
90.6	78	Low	21T	20T	247.4	213	High	21T	20T
95.3	82	Low	21T	19T	260.2	224	High	21T	19T
99.9	86	Low	21T	18T	274.2	236	High	21T	18T
105.7	91	Low	21T	17T	290.4	250	High	21T	17T
112.7	97	Low	21T	16T	333.4	287	High	17T	12T
122.0	105	Low	17T	12T	352.0	303	High	18T	12T
128.9	111	Low	18T	12T	371.7	320	High	19T	12T
134.8	116	High	12T	21T	391.5	337	High	20T	12T
135.9	117	Low	19T	12T	410.1	353	High	21T	12T

For 157.9 mm (6. 2 in.) Row Spacing (Special Range)

Metering Rate		Sprockets		
kg/har	lb/acre	Special Range	Driver	Driven
173.2	155	12:12	12T	21T
182.2	163	12:12	12T	20T
191.1	171	12:12	12T	19T
201.6	180	12:12	12T	18T
213.6	191	12:12	12T	17T
244.9	219	12:12	17T	21T
256.9	229	12:12	17T	20T
270.3	241	12:12	17T	19T
288.2	257	12:12	20T	21T
318.1	284	12:12	21T	20T
334.5	299	12:12	21T	19T
352.4	315	12:12	21T	18T
373.3	333	12:12	21T	17T
428.6	383	12:12	17T	12T
452.5	404	12:12	18T	12T
477.9	427	12:12	19T	12T
503.3	449	12:12	20T	12T
527.1	471	12:12	21T	12T

For 157.9 mm (6. 2 in.) Row Spacing (Special High Range)

Metering Rate		Sprockets		
kg/har	lb/acre	Special Range	Driver	Driven
274.3	245	12:12	12T	21T
288.5	258	12:12	12T	20T
302.6	270	12:12	12T	19T
319.2	285	12:12	12T	18T
338.1	302	12:12	12T	17T
387.8	346	12:12	17T	21T
406.7	363	12:12	17T	20T
428.0	382	12:12	17T	19T
456.3	407	12:12	20T	21T
503.6	450	12:12	21T	20T
529.6	473	12:12	21T	19T
558.0	498	12:12	21T	18T
591.1	528	12:12	21T	17T
678.6	606	12:12	17T	12T
716.4	640	12:12	18T	12T
756.6	676	12:12	19T	12T
796.8	711	12:12	20T	12T
834.6	745	12:12	21T	12T

Density Conversion Chart

The fertilizer meter rate charts are based on fertilizer with a density of 1.04 kilograms per litre (65 pounds per cubic foot). If you are applying fertilizer of a different density, use the following table to convert the application rate.

Density, kg/l (lb/ft ³)	0.72 (45.0)	0.80 (50.0)	0.88 (55.0)	0.96 (60.0)	1.04 (65.0)	1.12 (70.0)	0.87 (75.0)	0.81 (80.0)
Conversion Factor	1.45	1.30	1.20	1.10	1.00	0.93	0.87	0.81

Example: Your fertilizer has a density of 0.72 kilograms per litre, and you want to apply 100 kilograms per hectare. Multiply desired application rate by the conversion factor.

$$100 \times 1.45 = 145$$

Adjust drill to setting closest to 145 kilograms per hectare.

Small Seeds Attachment

To set and calibrate the seeding rate on the optional small-seeds attachment, follow these steps.

1. Set seed-rate handle on small-seeds attachment to setting indicated on *Small Seeds Rate Chart*.
2. Calibrate small-seeds attachment to your material by following the steps under *Checking Seeding Rate*, page 3.

Small Seed Rate Charts

Optional Equipment

Seed-Rate-Handle Setting	5	10	15	20	25	30	35	40	45	50	55	60	65	70	75	80	85	90	95	100	
	Seeding Rate, Pounds per Acre/Kilograms Per Hectare																				
	Row Space																				
Alfalfa, Crimson Clover and Red Alsike	6.2 in.	0.0	2.2	3.5	4.8	6.0	7.5	8.7	9.8	11.2	12.5	13.8	15.1	16.4	17.5	18.6	20.2	21.4	22.9	24.0	25.2
	157.9mm	0.0	1.8	2.8	3.9	4.8	6.0	7.0	7.9	9.0	10.1	11.1	12.2	13.2	14.1	15.0	16.3	17.2	18.4	19.3	20.3
Annual Rye Grass, Kentucky Blue Grass and Fescue	6.2 in.	0.0	0.2	1.2	1.9	2.7	3.3	4.1	4.6	5.2	5.8	6.3	6.8	7.3	7.8	8.3	8.8	9.2	9.7	10.0	10.5
	157.9mm	0.0	0.2	1.4	2.2	3.1	3.8	4.8	5.3	6.0	6.7	7.3	7.9	8.5	9.1	9.6	10.2	10.7	11.3	11.6	12.2
Bermuda, Red Top, Unhulled Lespedeza, Sand, Sercia and Weeping Love Grass	6.2 in.	0.0	0.7	1.1	1.7	2.6	3.3	4.1	5.0	5.9	6.6	7.2	7.8	8.4	9.0	9.5	10.2	10.9	11.6	12.2	12.9
	157.9mm	0.0	0.8	1.3	2.0	3.0	3.8	4.8	5.8	6.9	7.7	8.4	9.1	9.8	10.5	11.0	11.8	12.7	13.5	14.2	15.0
Hulled Lespedeza, Red Clover and Sweet Clover	6.2 in.	0.0	1.5	3.4	5.2	7.1	9.0	11.3	13.2	15.3	17.0	19.0	20.8	22.5	24.5	26.4	28.3	30.1	32.1	33.8	35.6
	157.9mm	0.0	1.7	3.9	6.0	8.2	10.5	13.1	15.3	17.8	19.7	22.1	24.2	26.1	28.5	30.7	32.9	35.0	37.3	39.3	41.4
Orchard Grass	6.2 in.	0.0	0.0	0.3	0.7	0.9	1.3	1.5	2.0	2.4	2.8	3.3	3.5	3.9	4.4	4.8	5.0	5.5	5.7	6.1	6.3
	157.9mm	0.0	0.0	0.3	0.8	1.0	1.5	1.7	2.3	2.8	3.3	3.8	4.1	4.5	5.1	5.6	5.8	6.4	6.6	7.1	7.3
Millet and Reed Canary	6.2 in.	0.4	1.4	2.4	3.5	4.4	5.5	6.5	7.5	8.5	9.5	10.5	11.5	12.5	13.6	14.6	15.6	16.6	17.6	18.5	19.0
	157.9mm	0.5	1.6	2.8	4.1	5.1	6.4	7.6	8.7	9.9	11.0	12.2	13.4	14.5	15.8	17.0	18.1	19.3	20.4	21.5	22.1
Canary Grass, Canola, Timothy and Ladino Clover	6.2 in.	0.0	1.1	2.1	3.3	4.7	6.1	7.6	9.2	10.7	12.2	13.8	15.5	17.0	18.5	20.3	21.7	23.4	25.4	27.3	29.2
	157.9mm	0.0	1.3	2.4	3.8	5.5	7.1	8.8	10.7	12.4	14.2	16.0	18.0	19.7	21.5	23.6	25.2	27.2	29.5	31.7	33.9
Sudan and Bird's-Foot Trefoil	6.2 in.	0.0	1.7	3.3	5.2	6.8	8.7	10.7	12.7	14.7	16.8	19.2	21.2	23.4	25.6	28.0	29.9	32.1	34.2	36.3	38.4
	157.9mm	0.0	2.0	3.8	6.0	7.9	10.1	12.4	14.8	17.1	19.5	22.3	24.6	27.2	29.7	32.5	34.7	37.3	39.7	42.2	44.6