



Grease Bank Kit 7- and 10-Foot EWNT Drills

Used with:

- 705 (all models)
- 1005 (all models)



When you see this symbol, the subsequent instructions and warnings are serious - follow without exception. Your life and the lives of others depend on it!

General Information

These instructions explain how to install a Grease Bank Kit. These kits greatly improve the ease of lubricating coulters by adding one or two bulkheads, with zerks and tubing to new grease adaptors at the coulters.

These instructions apply to an installation of either:

Kit	Kit Description
151-126A	7' GREASE BANK KIT
151-127A	10' GREASE BANK KIT

Each kit upgrades an entire drill. There will be a few parts left over if your drill has less than the maximum possible number of coulters.

Due to shipping regulations, the kit does not include any touch-up paint to restore the welded areas. Your Great Plains dealer can provide it as Great Plains part:

821-001C PAINT GP GREEN SPRAY CAN

The grease bank does not serve the coulters disk bearing zerks (if present), as they rotate and cannot accept a fixed lubrication tube.

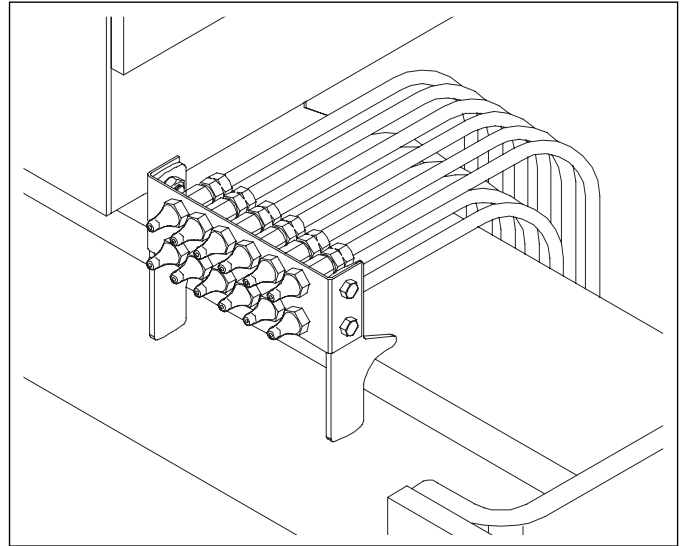

Figure 1
Completed Grease Bank

27150

Tools Required

- wire or stick welder and welding tarps,
- basic hand tools, including:
 - heavy clamp or self-clamping pliers,
 - a pipe or tubing cutter,
 - wire brush, sand paper,
- grease and grease gun,
- green touch-up paint, and;
- suitable tractor for positioning drill.

Notations and Conventions

“Left” and “Right” are facing in the direction of machine travel. An orientation rose in the line art illustrations shows the directions of Left, Right, Front, Back, Up, Down.

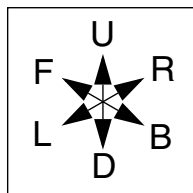

Call-Outs

- ① Single-digit callouts identify components in the currently referenced Figure or Figures. These numbers may be reused for different items from page to page.
- ⑪ to ⑫ Two-digit callouts in this range reference new parts from the new parts lists beginning on page 8.
- ⑤① This two-digit callout references an affected existing part from the table on page 8. The description matches that in your Parts Manual.

Before You Start

Review these instructions, with the following objectives at each step:

- **Safety:** welding is required and represents a potential fire and personal injury hazard - plan the location and the work to minimize risks.
- **Inventory:** examine any called-for items and make sure all parts are present.
- **Comprehension:** make sure you understand where each part or assembly is installed, and what tools are required for the task.

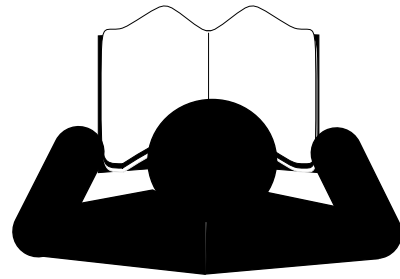

Pre-Assembly Preparation

Work Location

1. Move the drill to a location with:
 - a non-flammable surface beneath,
 - adequate illumination,
 - protection from weather (for painting), and;
 - access to power for any power tools.



CAUTION

There will be sparks from welding. Dry grass, wood floors, or areas with spills of flammable fluids are not suitable locations for the work.

Prepare Drill

2. Raise the drill and install transport locks. The work may be performed with the drill lowered, but access to the coultter zerks is easier when raised.
3. Block the tires and install the parking jack.
4. Disconnect all hydraulic and electrical connections at the hitch. Secure hoses and cables to prevent ground contact.
5. Unhitch the tractor and move it away from any potential contact with the drill frame (to prevent possible system damage if electric welding is used).

Select Bulkhead Locations

Pre-Assemble Bulkhead(s)

Refer to Figure 2

6. For 705, select one set of the following.
For 1005, select two sets (the double quantity):

Qty	Call	Part	Description
1 or 2	12	197-194D	GREASE BANK MOUNT
2 or 4	13	197-258D	GREASE BANK MOUNT PLATE
4 or 8	18	802-004C	HHCS 1/4-20X3/4 GR5
4 or 8	19	803-006C	NUT HEX 1/4-20 PLT
4 or 8	20	804-006C	WASHER LOCK SPRING 1/4 PLT
4 or 8	21	804-007C	WASHER FLAT 1/4 SAE PLT

7. Loosely assemble two mount plates 13 inside the ends of the mount 12, with the weld ears 1 facing away from the mount.
8. Position the assembly anywhere along the top from edge of the drill's mainframe tool bar. Make sure the lower rear edge (2, the weld region) is in continuous contact with the tool bar, and tighten the nuts to about half of final torque (the bulkhead is disassembled and re-assembled in later steps).

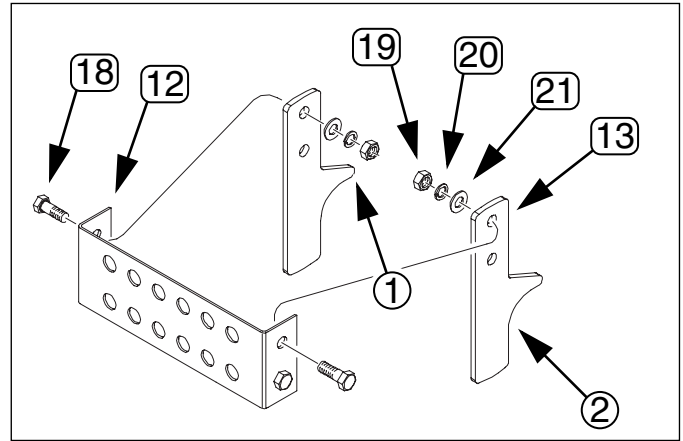

Figure 2
Pre-Assemble Bulkhead

27142

Determine Mounting Location

The ideal location for the bulkhead(s) depends on drill configuration, particularly frame-mounted coulters. Choose locations that provide full access to the zerk openings for maintenance, and ample clearance both mount brackets for welding.

Refer to Figure 3

The suggested location for the single 705, and right 1005 bulkhead is toward the right end of the tool bar, near or in front of the right arm pivot plate 3.

On the 1005, the second bulkhead is located at the left end of the tool bar, near or in front of the left arm pivot plate 4.

9. Using a bulkhead assembly as a guide, mark the outline of each plate at the weld location.

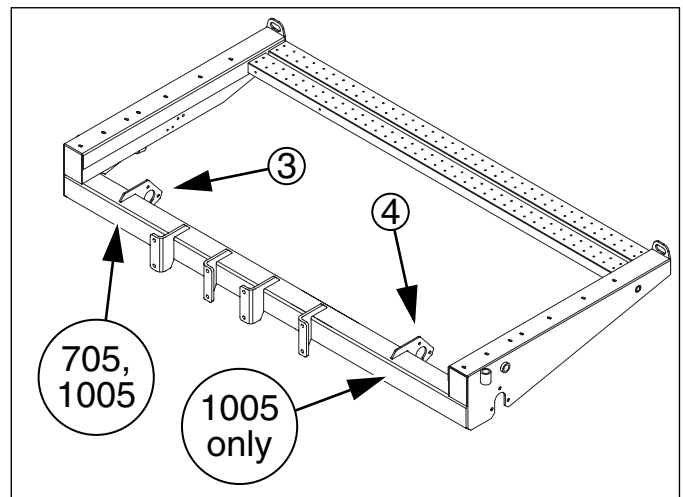

Figure 3
705/1005 Bulkhead Locations

27143

Prepare Weld Areas

10. Use a wire brush and/or sandpaper to remove the paint from the toolbar at the weld location, plus the area about 1/2 in (1.3cm) on either side.
11. Use sandpaper to remove the paint on the welding edge of the mount plates (2 in Figure 2 above), plus the area about 1/2 in (1.3cm) on either side at that edge.

Weld Bulkheads

Tack Weld Mount Plates

Refer to Figure 4

If you prefer to fully protect the mount (12), not shown) from welding damage, disassemble the bulkhead and space the mount plates (13) $5\frac{9}{16}$ in (14.1cm) apart. Be sure to align the holes and keep the plates vertical and in full contact with the tool bar.

- Tack weld the mount plates at each desired location, and allow to cool. Tack at least four points on each plate, at least two on each side of the plate.

Disassemble Bulkhead(s)

- If the bulkhead was pre-assembled for tack welding, disassemble it now, and save all parts.

If the bulkhead was disassembled for tack welding, check the spacing with a trial re-assembly, then disassemble and save all parts.

Final Weld Bulkhead(s)

- Finish weld each plate to the tool bar, using a $\frac{1}{8}$ in (3.2mm) fillet weld.
- Allow to fully cool.

Restore Painted Surfaces

- Use a wire brush or file as necessary to remove weld burrs or scorched paint. Sand surfaces.
- Apply green touch up paint and allow to dry.

Final Bulkhead Assembly

Refer to Figure 5

- Re-assemble mount (12) on the mount plates (13), using the saved fasteners. Torque bolts and nuts to final values.

Allocate Zerks

Refer to Figure 6 on page 5

- If not already known, count the number of frame-mounted coulters on the drill.
- Select that (as needed) number of:

Qty	Call	Part	Description
(a.n.)	(14)	800-130C	GREASE ZERK STRAIGHT 1/8-27NPT
(a.n.)	(16)	800-158C	FTG TUBE,CONNECTOR 1/8 FNPT

- On drill model 1005, split the number into two equal groups. If the total is an odd number, put the odd set into the group for the right bulkhead.

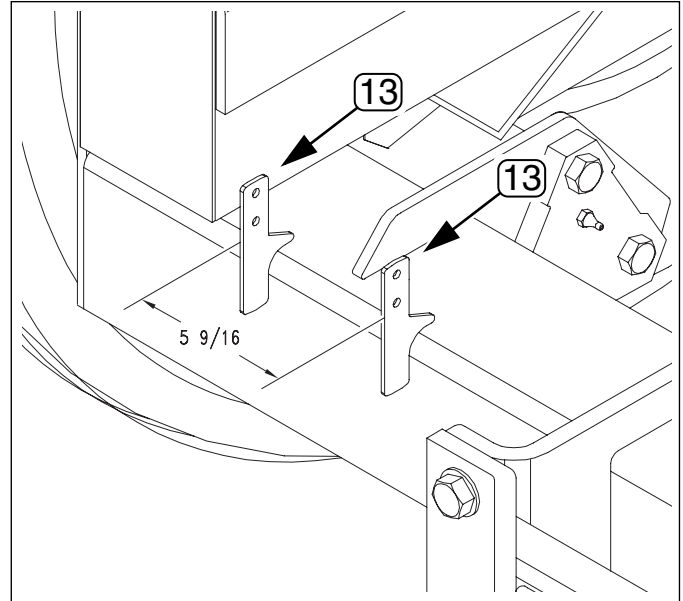

Figure 4
Weld Mount Plates

27144

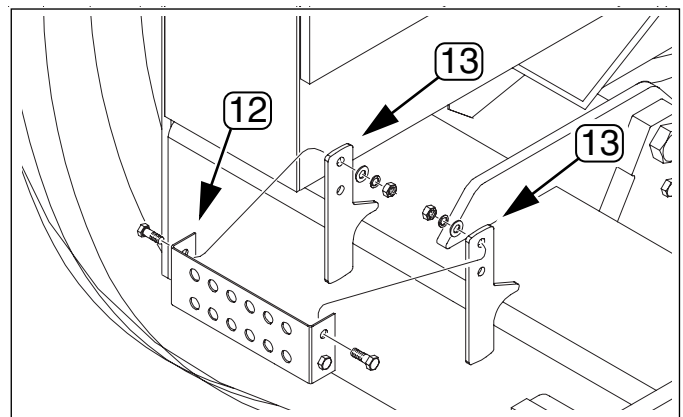

Figure 5
Final Bulkhead Assembly

27145

Install Zerks on Bulkhead

Refer to Figure 6

Note: The fitting connector (16) has three parts:

- ① the NPT and compression body,
- ② an internal ferrule, and;
- ③ a cap (or jam nut).

When assembling to the zerk (14), tighten only the NPT body. Do not tighten the cap until tube insertion in a later step. If you remove the cap, be sure to capture and save the ferrule.

22. Starting at the inside end of the bottom row of holes, insert the 1/8MNPT threaded end of a zerk (14) through the front of the bulkhead, and secure with the 1/8FNPT body of a fitting connector (16).

Torque to 1-2 turns past finger tight.

23. If the ferrule and cap were left on the connector, make sure the cap is finger tight to prevent loss.

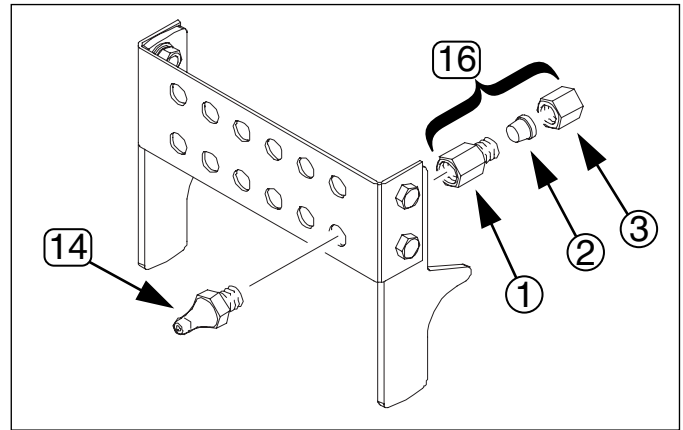

Figure 6
Bulkhead Zerk Installation

27146

Replace Existing Coultter Zerks

Remove Old Zerks

Refer to Figure 7

24. At each coultter, clean away any dirt or debris at the zerk on the coultter arm pivot, near the forward end of the spring.

Note: This is not the zerk on the disk hub.

25. Remove the existing:

Qty	Call	Part	Description
ea	(51)	800-001C	GREASE ZERK STRAIGHT 1/4-28

This removed zerk (51) is not re-used.

Install New Adaptors

Refer to Figure 7

26. Select one new:

Qty	Call	Part	Description
(a.n.)	(17)	800-211C	GREASE ADAPT 1/4-28M X 1/4 TB

27. Screw the adaptor into the 1/4-28 threaded hole formerly occupied by the zerk, and torque it to 6 ft-lbs (8.5 N-m).

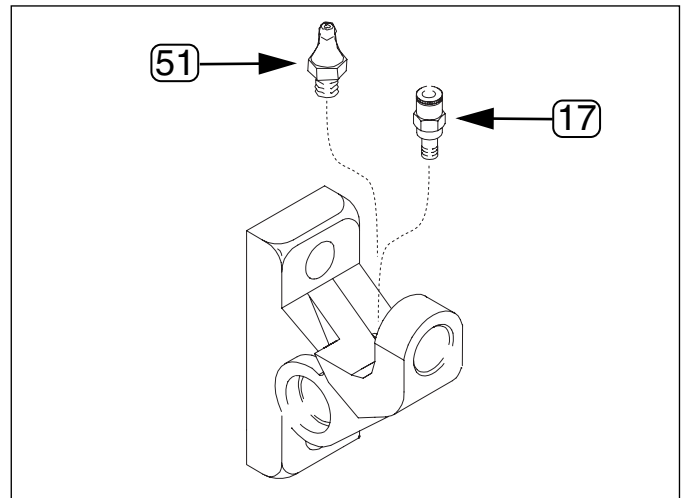

Figure 7
Replace Coultter Zerk

27148

Install Tubing

28. Select the:

Qty	Call	Part	Description
14	(15)	800-150C	CABLE TIE 22.2 LONG REL.
50 or 75 ft	(22)	990-109R	TUBE NYLON 1/4OD X 062WL

The tubing from the grease bank to the coulters is supplied as a single coil, and must be cut-to-length for each bulkhead-to-adaptor run. Expect some amount of tubing to be left over, even with a maximum number of coulters.

Pre-Position Ties

29. Starting about 5in (13cm) from the right end of the tool bar, lay a cable tie at regular intervals along the top of the tool bar.
For the model 705, this is about every 5 $\frac{1}{4}$ in (13.3cm).
For the model 1005, this is about every 7 $\frac{3}{4}$ in (19.5cm).
30. When the spacing is satisfactory, loop each tie around the bar, and insert the tip into the clasp a short distance (do not tighten the ties at this time).

Route, Cut and Terminate Tubing

For the model 1005, start with the center coulters (odd row count) or the coulters just right of center (even row count).

For each coulters:

31. Route an end of the uncut tubing (22) from the bulkhead to the coulters.
If there is an unoccupied hole (1) in the mount, routing the tubing through it may be helpful.
- Route into the nearest tie loop in the direction of the coulters, then along the tool bar through ties up to the coulters mount, and then down to the coulters.
32. Leave enough slack in the tubing for later tightening of the ties, and avoiding sharp bends (which may kink). Avoid excess slack and sags.
33. Cut the tubing (22) at the bulkhead and remove it from any hole used for routing.
34. Remove cap (2) and ferrule (3) from the adaptor (4).
35. Slide the non-threaded end of the cap (2) and then the large end of the ferrule (3) onto the tubing (22).
36. Press the tubing end fully into the adaptor body (4).
37. Secure the tubing with the cap (2).
38. At the coulters end, press the tubing end fully into the grease adaptor.

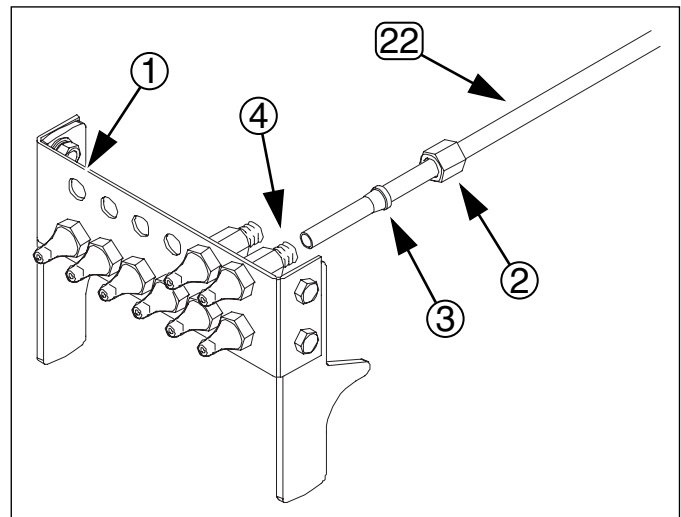

Figure 8
Bulkhead Tubing Installation

27149

Secure Tubing

39. When all the coulters have had tubing routed and attached, begin drawing up the cable ties in stages.

Leave slack for gentle bends at the back of each grease bank.

Make sure tubing is flat against the tool bar.

Leave slack for gentle bends down to coulters, and slack for possible future coulter height adjustments.

Closeout

40. At each bank zerk, pump until only grease (and no air) emerges at the coulter pivot.

There should be minimal resistance until grease reaches the coulter, and then only modest resistance.

If there is strong resistance, check for defective zerk, fitting blockage, tubing blockage and grease pump malfunction.

If resistance suddenly drops, check for tubing leaks or disconnections.

Maintenance

Coulter Pivot Arms: At Grease Bank

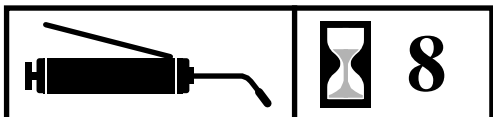

1 zerk each pivot; 1 or 2 banks

Type of Lubrication: Grease

Quantity: 5 pumps or until grease emerges

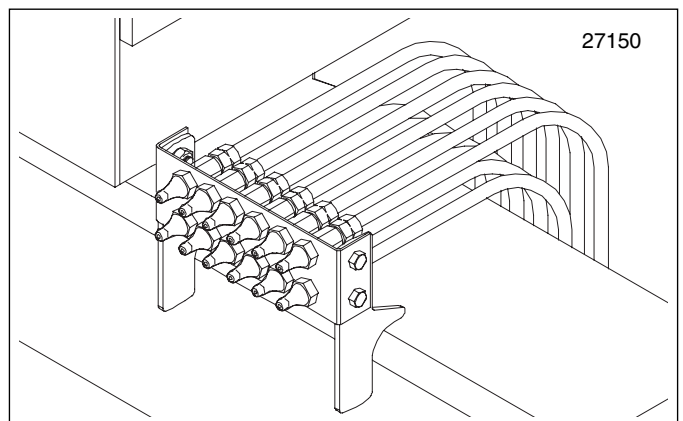

Parts Lists

New Parts

This manual covers the installation of two different grease bank kits. Parts are listed for each kit separately.

The part call-out numbers in this list match all Figures in these installation instructions. Part descriptions match those in your updated Parts Manual.

Quantities are units ("ea") unless otherwise noted. The kits are "universal" and include enough zerks, adaptors and tubing for maximum-row-count drills. If your drill has fewer row units, parts will be left over.

Kit Contents

151-126A 7' GREASE BANK KIT

151-127A 10' GREASE BANK KIT

Callout	Quantity in Kit		Part Number	Part Description
	151-126A	151-127A		
(11)	1	1	151-128M	MANUAL 7&10 GREASE BANK KIT
(12)	1	2	197-194D	GREASE BANK MOUNT
(13)	2	4	197-258D	GREASE BANK MOUNT PLATE
(14)	11	16	800-130C	GREASE ZERK STRAIGHT 1/8-27NPT
(15)	14	14	800-150C	CABLE TIE 22.2 LONG REL.
(16)	11	16	800-158C	FTG TUBE,CONNECTOR 1/8 FNPT
(17)	11	16	800-211C	GREASE ADAPT 1/4-28M X 1/4 TB
(18)	4	8	802-004C	HHCS 1/4-20X3/4 GR5
(19)	4	8	803-006C	NUT HEX 1/4-20 PLT
(20)	4	8	804-006C	WASHER LOCK SPRING 1/4 PLT
(21)	4	8	804-007C	WASHER FLAT 1/4 SAE PLT
(22)	50 ft	75 ft	990-109R	TUBE NYLON 1/4OD X 062WL

Existing Part Affected

The following existing part is involved in the kit installation. The Disposition column indicates whether the part is left in place, moved or not re-used.

The part call-out number in the list matches all Figures in the installation instructions. The description matches that in your drill Parts manual.

Callout	Part No.	Part Description	Part Disposition
(51)	800-001C	GREASE ZERK STRAIGHT 1/4-28	Removed and not re-used.

Abbreviations

FTG	Fitting
HEX	Hexagonal (6-sided)
HHCS	Hex Head Cap Screw (Bolt)
NPT	(Female/Male) National Pipe Thread

OD	Outside Diameter
PLT	Plated
SAE	Society of Automotive Engineers (standards)
WL	Working Length

Great Plains Manufacturing, Inc.

Corporate Office P.O. Box 5060
Salina, Kansas 67402-5060 USA