



**Great Plains**  
Manufacturing, Inc.

## *Seed Rate and Fertilizer Application Charts for 3S- 4000 Three-Section Fold- ing Drill*

The following pages are to assist in the proper setting of seeding and fertilizer application rates for the 3S-4000 Three-Section Folding Drill. The rates indicated in the charts are approximate values. To assure the most accurate seeding rate it is recommended that the drill be calibrated for the desired seed at the time of planting.

---

## Table of Contents

Seed Rate Calibration . . . . .	3
Changing Drive Types . . . . .	4
Setting Seed Rate Handle . . . . .	5
Positioning Seed Cup Doors . . . . .	5
Checking Seeding Rate . . . . .	6
Equations for calibrating seeding rate: . . . . .	6
Seed Rate Charts . . . . .	7
Fertilizer Rate Calibration . . . . .	11
Fertilizer Meter Rate Charts . . . . .	13
Density Conversion Chart . . . . .	13

This section covers basic field and maintenance adjustments. Before going to the field, set the seeding rate and adjust seeding depth. Check drive chains and disk scrapers periodically during the season.

## Seed Rate Calibration

Calibrating the seeding rate requires four steps:

- changing drive sprockets,
- setting seed-rate handle,
- positioning seed-cup doors, and
- checking seeding rate.

Refer to the seed-rate charts. These charts list proper sprocket sizes and seed-rate-handle settings for various seeds and seeding rates.

The seed-rate charts are based on cleaned, untreated seed of average size and test weight. The charts are based on 11L-15 8-ply rib implement tires and 265/70B16 skid steer tires. Many factors will affect seeding rates including foreign material, seed treatment, seed size, seed weight, field conditions, tire pressure and test weight. You likely will need to make minor adjustments. Set and check the seeding rate using the procedures below, then readjust the rate as necessary.

For correct drive type, refer to seed-rate charts beginning on page 7. The charts list drive types as 1, 2, 3 or 4. Refer to Table 1 for correct sized sprocket for each drive type.

Drive Type	Sprocket	Speed
Type 1	72-tooth	Slowest
Type 2	34 tooth	Two Times Faster Than Type 1
Type 3	23-tooth	Three Times Faster Than Type 1
Type 4	14-tooth	Five Times Faster Than Type 1

Table 1

**Changing Drive Types**

*Refer to Figure 1*

1. Loosen idlers and remove drive chain.
2. Remove lynch pin and rearrange sprockets on shaft.

*Refer to Figure 2*

3. Reroute drive chain to your particular drive type as shown.
4. Reassemble drive.
5. Set the same drive type on all drill sections.

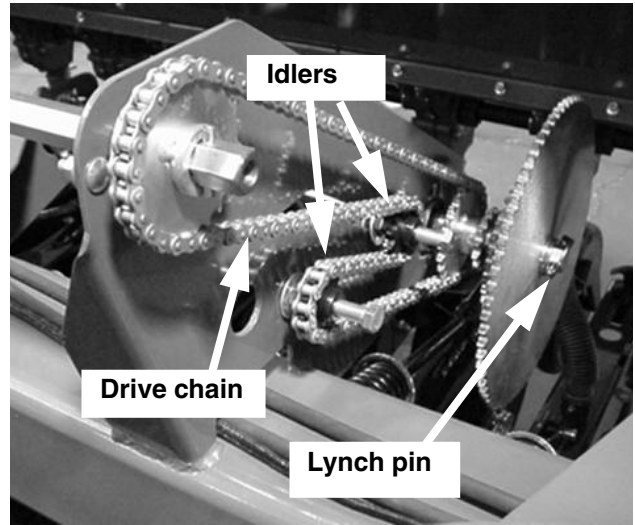

**Figure 1**  
**Drive Type Sprockets**

18838

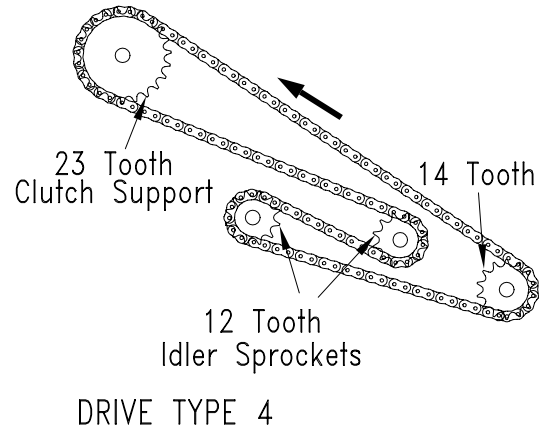
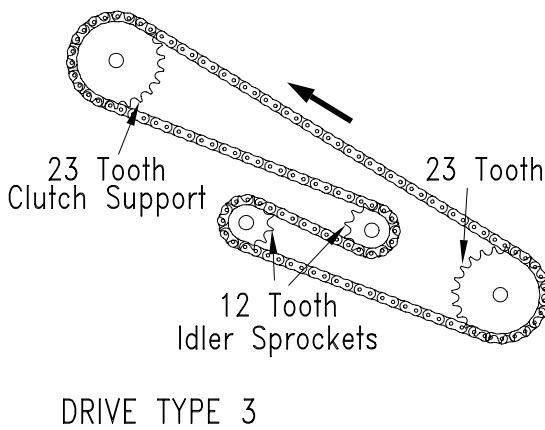
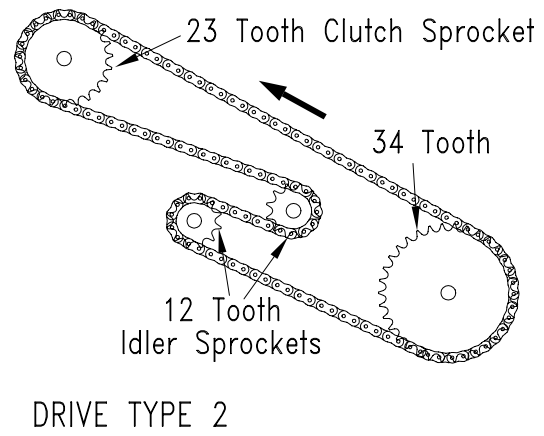
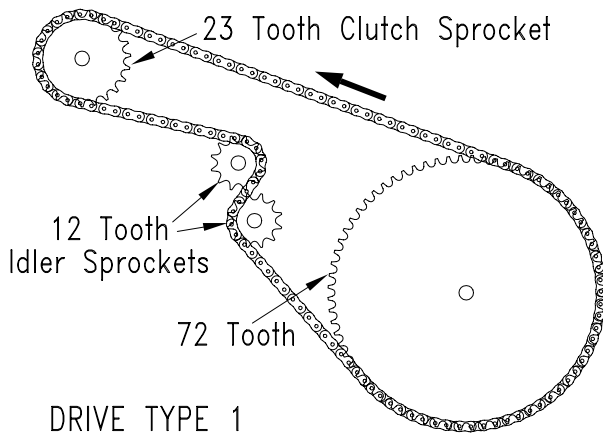

**Figure 2**  
**Drive Type Sprockets and Chain Routings**

18839

### Setting Seed Rate Handle

*Refer to Figure 3*

There is a seed rate adjustment handle for each drill section. Position handles to the setting indicated on the seed-rate charts.

To adjust handle, loosen wing nut under handle and slide handle until indicator lines up with correct setting.



**Figure 3**  
**Seed Rate Adjustment**

18840

### Positioning Seed Cup Doors

*Refer to Figure 4*

For wheat and other small seeds, move seed cup door handles to highest position. For soybeans and other large seeds, lower handles to second position. If excessive seed cracking occurs, lower handles to third position. For seed cup clean out, move handles to fourth, wide open. Make sure all handles are in the same position before drilling.

NOTE: Do not open seed cup door to wide open position with seed in the box unless complete cleanout is desired. The door may be difficult to close off once it is opened.

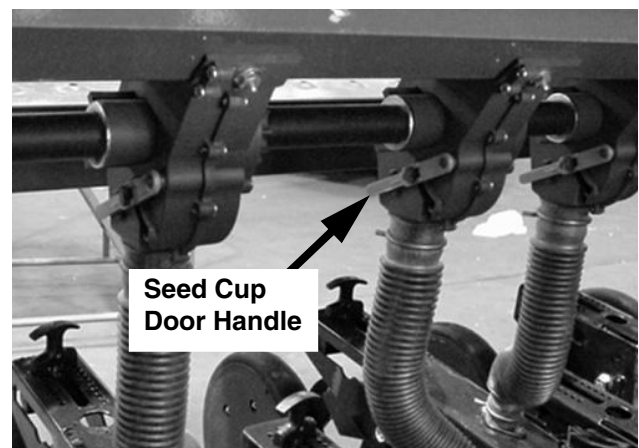

**Figure 4**  
**Seed Cup Door Adjustment**

18841

## Checking Seeding Rate



### WARNING!

*You may be severely injured or killed by being crushed from a falling implement or openers. Always have transport locks in place and frame sufficiently blocked up when working on the drill.*



1. Jack up drive gauge wheel(s) and rotate them to see that seed cups and drives are working properly and free from foreign material.
2. Check that your gauge-wheel tires are 11L-15 8-ply rib implement and properly inflated. Refer to *Tire Inflation Chart*, page 84 of the operator's manual.
3. Record weight of an empty container large enough to hold seed metered for one acre.
4. Place several pounds of seed over three seed cups on an outside end of drill box. Pull seed tubes off of these three openers.
5. Turn drive wheel several times to fill seed cups. Turn wheel until seed drops to ground from each seed cup.
6. Place empty container under three tubes to gather metered seed.
7. Turn drive wheel until one acre is tallied on acremeter (130 wheel rotations). While turning, check that cups have plenty of seed coming into them.
8. Weigh metered seed. Subtract initial weight of container. Divide by three. Multiply by number of openers on your drill to determine the total of pounds-per-acre seeded. If this figure is different than desired, reset sprockets or seed rate handles accordingly.

**NOTE:** You may want to repeat calibration procedure if your results vary greatly from seed-rate chart.

9. When drilling, check seeding rate by noting acres drilled, amount of seed added to drill and seed level in drill box. If you are seeding more or less than desired, adjust rate slightly to compensate for field conditions.

### Equations for calibrating seeding rate:

$$\frac{\text{measured seed} - \text{empty container}}{3 (\text{number of seed cups measured})} = \text{pounds per cup}$$

$$\text{pounds per cup} \times \text{number of openers} = \text{pounds per acre}$$

## Seed Rate Charts (pounds per acre)

Setting number		0	5	10	15	20	25	30	35	40	45	50	55	60	65	70	75	80	85	90	95	100	
Alfalfa Drive Type 1 (Based on 60#/bu)	Spacing	6"	2	6	8	12	15	19	23	27	32	37	41	45	50	54	59	63	69	74	79	82	84
		7.5"	2	4	7	10	12	15	18	22	25	29	33	36	40	43	47	51	55	59	63	65	67
		10"	1	3	5	7	9	12	14	16	19	22	25	27	30	33	35	38	41	44	48	49	50
Barley Drive Type 1 (Based on 51#/bu)	Spacing	6"	2	5	8	11	14	18	22	26	30	35	39	43	48	53	57	62	66	69	73	73	74
		7.5"	2	4	6	9	12	15	18	21	24	28	31	35	38	42	46	49	52	55	58	59	59
		10"	1	3	5	6	9	11	13	16	18	21	23	26	29	32	34	37	39	42	44	44	44
Barley Drive Type 2 (Based on 51#/bu)	Spacing	6"	4	9	16	22	30	37	45	54	62	71	76	87	96	104	114	123	133	142	152	154	156
		7.5"	3	7	13	17	24	30	36	43	49	57	64	70	77	83	91	98	106	114	121	123	125
		10"	2	5	10	13	18	22	27	32	37	43	48	52	58	63	68	74	80	85	91	92	94
Barley Drive Type 4 (Based on 51#/bu)	Spacing	6"	9	21	39	53	73	90	110	131	151	174	194	213	234	255	278	300	325	348	371	377	382
		7.5"	7	17	31	42	58	72	88	105	121	139	155	170	188	204	222	240	260	279	297	301	306
		10"	5	13	23	32	44	54	66	79	91	104	117	128	141	153	167	180	195	209	222	226	230
Buck Wheat Drive Type 3 (Based on 48#/bu)	Spacing	6"	0	11	21	29	42	52	65	78	92	107	123	136	150	165	180	195	209	224	240	242	245
		7.5"	0	9	17	24	34	42	52	62	74	85	99	109	120	132	144	156	167	179	192	194	196
		10"	0	7	13	18	25	31	39	47	55	64	74	81	90	99	108	117	126	134	144	145	147
Canola or Rape Drive Type 1 (Based on 51#/bu)	Spacing	6"	0	4	8	11	14	18	21	25	29	32	36	39	43	47	51	54	59	63	68	69	71
		7.5"	0	3	6	9	11	14	17	20	23	26	29	32	34	37	40	43	47	50	54	55	57
		10"	0	2	5	6	9	11	13	15	17	19	22	24	26	28	30	33	35	38	41	42	43
Flax or Sudan Drive Type 1 (Based on 55#/bu)	Spacing	6"	0	4	8	12	16	20	24	28	33	37	42	46	50	54	59	65	70	76	82	83	85
		7.5"	0	3	7	9	13	16	19	23	26	30	34	37	40	44	47	52	56	61	66	67	68
		10"	0	2	5	7	10	12	15	17	20	22	25	27	30	33	35	39	42	45	49	50	51
Millet Drive Type 1 (Based on 60#/bu)	Spacing	6"	1	5	8	12	16	20	23	27	32	36	40	44	49	52	57	62	66	71	76	77	78
		7.5"	1	4	7	9	13	16	19	22	25	29	32	35	39	42	46	49	53	57	61	62	63
		10"	1	3	5	7	9	12	14	16	19	21	24	26	29	32	34	37	40	43	46	46	47
Milo Drive Type 1 (Based on 60#/bu)	Spacing	6"	0	5	9	13	18	23	28	34	39	45	52	57	63	69	75	81	87	92	98	100	102
		7.5"	0	4	7	10	14	18	22	27	31	36	41	45	50	55	60	65	69	73	78	80	82
		10"	0	3	5	8	11	14	17	20	23	27	31	34	38	41	45	49	52	55	59	60	61
Oats Drive Type 3 (Based on 37#/bu)	Spacing	6"	0	5	12	17	24	32	39	47	55	63	72	80	88	96	105	113	121	130	139	140	140
		7.5"	0	4	10	14	19	25	31	37	44	51	58	64	70	77	84	90	97	104	111	112	112
		10"	0	3	7	10	14	19	23	28	33	38	43	48	53	58	63	68	73	78	83	84	84
Peas Drive Type 3 (Based on 61#/bu)	Spacing	6"	0	0	19	34	52	69	84	102	119	137	154	169	186	202	218	235	251	266	281	283	284
		7.5"	0	0	15	27	42	55	67	82	95	110	123	136	149	161	175	188	201	213	225	226	227
		10"	0	0	11	20	31	41	50	61	71	82	93	102	112	121	131	141	151	160	169	170	171
Pinto Bean Drive Type 1 (Based on 61#/bu)	Spacing	6"	0	0	9	13	17	24	30	35	41	47	53	58	64	69	74	81	85	91	97	96	96
		7.5"	0	0	7	10	14	19	24	28	33	38	42	47	51	55	60	65	68	73	77	77	77
		10"	0	0	5	8	10	14	18	21	25	28	32	35	38	41	45	49	51	54	58	58	58

Setting number	0	5	10	15	20	25	30	35	40	45	50	55	60	65	70	75	80	85	90	95	100		
Rice Short Grain Drive Type 3 (Based on 43#/bu)	Spacing	6"	3	11	18	28	38	46	56	64	73	84	96	107	117	128	139	148	167	165	174	174	174
		7.5"	2	9	14	23	31	37	44	51	59	67	77	85	94	102	111	118	125	132	139	139	139
		10"	2	7	11	17	23	27	33	38	44	50	57	64	70	77	83	89	94	99	105	105	105
Rice Short Grain Drive Type 4 (Based on 43#/bu)	Spacing	6"	5	18	29	46	63	74	91	104	120	137	156	174	191	209	226	241	255	269	284	284	284
		7.5"	4	14	24	37	50	60	72	83	96	109	125	139	153	167	181	193	204	215	227	227	227
		10"	3	11	18	28	38	45	54	62	72	82	94	105	115	125	136	145	153	162	170	170	170
Rice Long Grain Drive Type 3 (Based on 47#/bu)	Spacing	6"	0	0	13	22	32	42	53	61	71	81	90	98	107	116	125	135	144	153	161	167	173
		7.5"	0	0	11	17	25	34	42	49	57	65	72	79	85	92	100	108	116	123	129	134	138
		10"	0	0	8	13	19	25	32	37	42	49	54	59	64	69	75	81	87	92	97	100	104
Rice Long Grain Drive Type 4 (Based on 47#/bu)	Spacing	6"	0	0	22	35	52	68	86	100	115	132	146	160	174	188	204	220	235	250	263	273	282
		7.5"	0	0	17	28	41	55	69	80	92	105	117	128	139	151	163	176	188	200	210	218	226
		10"	0	0	13	21	31	41	52	60	69	79	88	96	104	113	123	132	141	150	158	164	169
Rye Drive Type 1 (Based on 57#/bu)	Spacing	6"	0	3	8	13	19	24	28	35	41	47	53	58	63	68	74	81	87	94	101	102	102
		7.5"	0	2	6	10	15	19	22	28	33	38	42	46	50	55	59	64	69	75	81	81	82
		10"	0	2	5	8	11	14	17	21	24	28	32	35	38	41	44	48	52	56	61	61	61
Soybeans Drive Type 1 (Based on 58#/bu)	Spacing	6"	0	3	8	13	19	23	29	34	39	45	49	55	61	66	71	77	82	87	93	93	93
		7.5"	0	2	6	11	15	19	23	27	31	36	40	44	49	53	57	62	65	70	74	74	75
		10"	0	2	5	8	12	14	17	20	24	27	30	33	37	40	43	46	49	52	56	56	56
Soybeans Drive Type 2 (Based on 58#/bu)	Spacing	6"	0	6	16	27	40	48	59	69	80	92	102	114	125	136	147	158	167	179	190	191	192
		7.5"	0	5	13	22	32	38	47	55	64	73	81	91	100	109	118	127	134	143	152	153	153
		10"	0	4	10	16	24	29	35	42	48	55	61	68	75	82	88	95	101	107	115	115	115
Soybeans Drive Type 3 (Based on 58#/bu)	Spacing	6"	0	12	23	40	60	71	89	101	116	131	148	164	181	196	214	228	248	265	284	284	284
		7.5"	0	9	18	32	48	57	71	81	93	105	119	131	145	157	171	182	199	212	227	227	227
		10"	0	7	14	24	36	42	53	61	70	79	89	98	108	118	128	137	149	159	170	170	170
Soybeans Drive Type 4 (Based on 58#/bu)	Spacing	6"	0	19	37	66	97	115	145	165	190	214	241	267	295	320	348	371	405	433	463	463	464
		7.5"	0	15	29	53	78	92	116	132	152	171	193	214	236	256	279	297	324	346	370	371	371
		10"	0	11	22	40	58	69	87	99	114	128	145	160	177	192	209	223	243	260	278	278	278
Sun flowers Drive Type 1 (Based on 28#/bu)	Spacing	6"	0	0	2	4	6	8	11	13	15	18	20	23	25	27	30	32	34	36	38	39	41
		7.5"	0	0	2	3	5	7	9	10	12	14	16	18	20	22	24	26	27	29	31	32	33
		10"	0	0	1	3	4	5	6	8	9	11	12	14	15	16	18	19	20	22	23	24	24
Wheat Drive Type 2 (Based on 64#/bu)	Spacing	6"	0	13	22	30	40	50	57	70	80	91	105	115	127	140	152	164	177	190	203	205	206
		7.5"	0	10	18	24	32	40	46	56	64	73	84	92	102	112	122	131	142	152	162	164	165
		10"	0	8	13	18	24	30	34	42	48	55	63	69	76	84	91	99	106	114	122	123	124
Wheat Drive Type 3 (Based on 64#/bu)	Spacing	6"	0	16	31	45	60	74	88	104	120	137	153	168	186	202	220	240	256	274	290	297	299
		7.5"	0	13	25	36	48	59	70	83	96	109	123	134	149	162	176	192	205	219	232	237	239
		10"	0	10	18	27	36	45	53	62	72	82	92	101	111	121	132	144	154	164	174	178	179
WheatGrass Drive Type 1 (Based on 23#/bu)	Spacing	6"	0	1	2	3	4	5	6	7	8	10	11	12	13	14	15	17	18	19	19	21	21
		7.5"	0	1	2	2	3	4	5	6	7	8	9	10	11	11	12	13	14	15	15	17	17
		10"	0	1	1	2	3	3	4	4	5	6	7	7	8	9	9	10	11	12	11	13	13

### Seed Rate Charts (kilograms per hectare)

Setting number		0	5	10	15	20	25	30	35	40	45	50	55	60	65	70	75	80	85	90	95	100	
Alfalfa Drive Type 1 (Based on .77 kg/L)	Spacing	15.24cm	0	7	10	13	17	21	26	30	35	40	46	51	56	62	67	72	77	82	87	91	95
		19.05cm	0	5	8	10	14	17	20	24	28	32	37	41	45	49	54	58	62	66	69	73	76
		25.40cm	0	4	6	8	10	13	15	18	21	24	27	31	34	37	40	43	46	49	52	55	57
Barley Drive Type 1 (Based on .66 kg/L)	Spacing	15.24cm	0	7	9	12	16	20	24	29	34	39	45	50	55	60	65	70	74	77	80	82	83
		19.05cm	0	5	7	10	12	16	19	23	27	31	36	40	44	48	52	56	59	62	64	66	67
		25.40cm	0	4	5	7	9	12	14	17	20	24	27	30	33	36	39	42	44	46	48	49	50
Barley Drive Type 2 (Based on .66 kg/L)	Spacing	15.24cm	0	14	19	25	32	40	50	60	70	81	92	103	114	124	134	143	151	158	164	169	172
		19.05cm	0	11	15	20	26	32	40	48	56	65	73	82	91	99	107	114	121	127	131	135	137
		25.40cm	0	8	11	15	19	24	30	36	42	49	55	62	68	74	80	86	91	95	99	101	103
Barley Drive Type 4 (Based on .66 kg/L)	Spacing	15.24cm	0	32	45	61	80	100	122	145	169	194	219	245	270	295	319	343	365	385	404	420	434
		19.05cm	0	26	36	49	64	80	97	116	135	155	175	196	216	236	256	274	292	308	323	336	347
		25.40cm	0	19	27	37	48	60	73	87	101	116	132	147	162	177	192	206	219	231	242	252	261
Buck Wheat Drive Type 3 (Based on .62 kg/L)	Spacing	15.24cm	0	21	26	34	44	56	71	86	103	121	140	158	177	195	212	228	243	256	267	276	282
		19.05cm	0	17	21	27	35	45	56	69	83	97	112	127	141	156	170	183	195	205	214	221	225
		25.40cm	0	13	16	20	26	34	42	52	62	73	84	95	106	117	127	137	146	154	160	165	169
Canola or Rapeseed Drive Type 1 (Based on .66 kg/L)	Spacing	15.24cm	0	6	9	12	16	19	23	27	32	36	40	45	49	53	58	62	66	70	74	77	81
		19.05cm	0	5	7	10	13	16	19	22	25	29	32	36	39	43	46	50	53	56	59	62	65
		25.40cm	0	4	5	7	9	12	14	16	19	22	24	27	29	32	35	37	40	42	44	46	48
Flax or Sudan Drive Type 1 (Based on .71 kg/L)	Spacing	15.24cm	0	7	10	13	17	22	27	31	37	42	47	53	58	64	69	74	79	84	89	93	97
		19.05cm	0	5	8	11	14	17	21	25	29	34	38	42	47	51	55	59	63	67	71	74	77
		25.40cm	0	4	6	8	10	13	16	19	22	25	28	32	35	38	41	45	48	50	53	56	58
Millet Drive Type 1 (Based on .77 kg/L)	Spacing	15.24cm	0	6	9	13	17	21	26	30	35	40	46	51	56	61	66	70	75	79	83	86	89
		19.05cm	0	5	8	10	13	17	21	24	28	32	36	41	45	49	53	56	60	63	66	69	71
		25.40cm	0	4	6	8	10	13	15	18	21	24	27	30	33	36	39	42	45	47	50	52	53
Milo Drive Type 1 (Based on .77 kg/L)	Spacing	15.24cm	0	7	10	14	19	25	31	37	44	51	58	65	72	79	85	92	97	103	108	112	115
		19.05cm	0	5	8	12	16	20	25	30	35	41	46	52	57	63	68	73	78	82	86	89	92
		25.40cm	0	4	6	9	12	15	19	22	26	31	35	39	43	47	51	55	58	62	65	67	69
Oats Drive Type 3 (Based on .48 kg/L)	Spacing	15.24cm	0	10	14	20	26	34	42	52	61	71	82	92	102	112	121	130	138	145	151	156	159
		19.05cm	0	8	11	16	21	27	34	41	49	57	65	73	82	89	97	104	110	116	121	124	127
		25.40cm	0	6	9	12	16	20	25	31	37	43	49	55	61	67	73	78	83	87	91	93	95
Peas Drive Type 3 (Based on .79 kg/L)	Spacing	15.24cm	0	9	23	39	56	74	93	113	133	154	175	195	215	234	251	268	283	296	307	316	322
		19.05cm	0	8	19	31	44	59	74	90	107	123	140	156	172	187	201	214	226	237	246	253	258
		25.40cm	0	6	14	23	33	44	56	68	80	92	105	117	129	140	151	161	170	178	184	190	193
Pinto Bean Drive Type 1 (Based on .79 kg/L)	Spacing	15.24cm	0	6	10	14	20	26	32	39	46	53	60	67	74	80	87	92	97	102	105	108	109
		19.05cm	0	5	8	12	16	21	26	31	37	42	48	54	59	64	69	74	78	81	84	86	87
		25.40cm	0	4	6	9	12	15	19	23	27	32	36	40	44	48	52	55	58	61	63	65	66

Setting number		0	5	10	15	20	25	30	35	40	45	50	55	60	65	70	75	80	85	90	95	100	
Rice Short Grain Drive Type 3 (Based on .55 kg/L)	Spacing	15.24cm	0	16	22	31	40	50	61	73	85	98	110	122	135	146	157	167	176	184	190	195	198
		19.05cm	0	13	18	24	32	40	49	58	68	78	88	98	108	117	126	134	141	147	152	156	158
		25.40cm	0	9	13	18	24	30	37	44	51	59	66	73	81	88	94	100	106	110	114	117	119
Rice Short Grain Drive Type 4 (Based on .55 kg/L)	Spacing	15.24cm	0	26	37	50	65	82	100	119	139	159	179	200	219	238	256	272	287	300	310	318	323
		19.05cm	0	20	29	40	52	65	80	95	111	127	144	160	176	191	205	218	230	240	248	254	258
		25.40cm	0	15	22	30	39	49	60	71	83	95	108	120	132	143	154	163	172	180	186	191	194
Rice Long Grain Drive Type 3 (Based on .61 kg/L)	Spacing	15.24cm	0	4	15	25	36	47	58	69	80	90	101	112	122	132	142	152	161	170	179	187	195
		19.05cm	0	3	12	20	29	38	46	55	64	72	81	89	98	106	114	122	129	136	143	150	156
		25.40cm	0	3	9	15	22	28	35	41	48	54	61	67	73	79	85	91	97	102	107	112	117
Rice Long Grain Drive Type 4 (Based on .61 kg/L)	Spacing	15.24cm	0	7	24	41	59	77	94	112	130	147	165	182	199	216	232	248	263	277	291	305	317
		19.05cm	0	6	19	33	47	61	75	90	104	118	132	146	159	173	186	198	210	222	233	244	254
		25.40cm	0	4	14	25	35	46	57	67	78	88	99	109	119	129	139	149	158	166	175	183	190
Rye Drive Type 1 (Based on .74 kg/L)	Spacing	15.24cm	0	5	10	14	20	25	32	38	45	52	59	66	73	80	87	93	99	104	109	113	116
		19.05cm	0	4	8	11	16	20	25	31	36	42	47	53	59	64	69	74	79	83	87	90	93
		25.40cm	0	3	6	9	12	15	19	23	27	31	35	40	44	48	52	56	59	63	65	68	70
Soybeans Drive Type 1 (Based on .75 kg/L)	Spacing	15.24cm	0	6	10	15	20	26	31	38	44	51	57	64	70	76	82	87	92	97	101	104	106
		19.05cm	0	5	8	12	16	20	25	30	35	40	46	51	56	61	65	70	74	77	80	83	85
		25.40cm	0	3	6	9	12	15	19	23	26	30	34	38	42	46	49	52	55	58	60	62	64
Soybeans Drive Type 2 (Based on .75 kg/L)	Spacing	15.24cm	0	12	20	30	41	52	65	77	91	104	117	131	144	156	168	179	190	199	207	213	218
		19.05cm	0	10	16	24	33	42	52	62	72	83	94	104	115	125	134	143	152	159	165	171	175
		25.40cm	0	7	12	18	25	31	39	46	54	62	70	78	86	94	101	108	114	119	124	128	131
Soybeans Drive Type 3 (Based on .75 kg/L)	Spacing	15.24cm	0	15	30	45	61	78	96	115	133	152	171	190	209	227	244	261	276	291	304	316	326
		19.05cm	0	12	24	36	49	63	77	92	107	122	137	152	167	181	195	209	221	233	243	253	261
		25.40cm	0	9	18	27	37	47	58	69	80	91	103	114	125	136	146	156	166	174	182	189	196
Soybeans Drive Type 4 (Based on .75 kg/L)	Spacing	15.24cm	0	25	48	73	100	128	157	187	218	248	279	310	340	370	398	425	451	474	496	515	531
		19.05cm	0	20	39	59	80	102	126	150	174	199	223	248	272	296	318	340	360	379	397	412	425
		25.40cm	0	15	29	44	60	77	94	112	131	149	168	186	204	222	239	255	270	285	297	309	319
Sun flowers Drive Type 1 (Based on .36 kg/L)	Spacing	15.24cm	0	0	2	5	7	9	12	14	17	20	23	26	28	31	34	36	38	41	42	44	46
		19.05cm	0	0	2	4	5	7	9	12	14	16	18	20	23	25	27	29	31	32	34	35	37
		25.40cm	0	0	1	3	4	6	7	9	10	12	14	15	17	19	20	22	23	24	25	27	27
Wheat Drive Type 2 (Based on .83 kg/L)	Spacing	15.24cm	0	21	26	33	42	52	64	76	90	104	118	133	147	161	175	188	200	211	220	228	234
		19.05cm	0	17	21	27	34	42	51	61	72	83	95	106	118	129	140	150	160	169	176	183	187
		25.40cm	0	13	16	20	25	31	38	46	54	62	71	80	88	97	105	113	120	127	132	137	141
Wheat Drive Type 3 (Based on .83 kg/L)	Spacing	15.24cm	0	26	37	49	63	79	97	115	135	154	175	195	215	235	254	272	289	304	318	329	339
		19.05cm	0	21	29	39	51	64	77	92	108	124	140	156	172	188	203	217	231	243	254	263	271
		25.40cm	0	16	22	30	38	48	58	69	81	93	105	117	129	141	152	163	173	182	191	198	203
WheatGrass Drive Type 1 (Based on .30 kg/L)	Spacing	15.24cm	0	1	2	3	5	6	7	8	10	11	12	13	15	16	17	18	19	20	21	22	23
		19.05cm	0	1	2	3	4	5	6	7	8	9	10	11	12	13	14	15	16	16	17	18	19
		25.40cm	0	1	1	2	3	3	4	5	6	6	7	8	9	10	10	11	12	12	13	13	14

## Fertilizer Rate Calibration

The 3S-4000 has chain drives powered off the gauge wheels to meter fertilizer. Adjust application rate by changing drive sprockets.

Fertilizer application rates will vary with fertilizer type, density and particle size. Relative humidity and field conditions can also affect application rates. The charts on page 13 are based on fertilizer with average particle size and a density of 65 pounds per cubic foot. Initially set rate according to charts, then calibrate drill to your material as described on this page.

Fertilizer metering is controlled by separate sprocket sets on each drill box. After setting and calibrating metering rate for one drill box, install same sprockets on other drill box.

1. Refer to fertilizer rate charts on page 13 to find correct sprocket sizes for your drill and desired meter rate.

**IMPORTANT:** The rate charts are for granular fertilizer with a density of 65 pounds per cubic foot. If you are applying fertilizer with a different density, use density conversion chart on page 13.

Refer to *Figure 5*

2. To switch between high and low range, loosen and slide idler sprocket out of chain.
  - For high range, switch to the 16-tooth sprocket and shorten chain by removing 16-pitch strand.
  - For low range, switch to the 44-tooth sprocket and lengthen chain by reinstalling 16-pitch strand.
  - Loosen the set screws on the drive sprocket and align the sprocket with the 16 or 44-tooth sprocket depending on which range you have selected to run. After sprocket is aligned, retighten set screws.
3. Move idler sprocket back into place so chain has 1/4-inch slack.

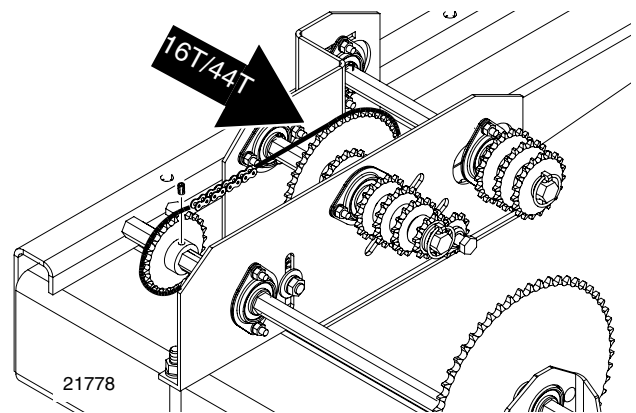

**Figure 5**  
**Hi/Low Range Sprocket**

**Refer to Figure 6**

1. To change driver/driven ratio loosen and slide idler sprockets out of chain. Remove lynch pins from shafts. Place correct sprockets on shafts. Store sprockets not used on ends of shafts. Reinstall chain and slide idlers back into place so chain has 1/4-inch slack.
2. Raise drill with tractor hydraulics so gauge wheels are off ground. Rotate gauge wheels to see that metering system is working properly and free from foreign material.
3. Check that your gauge-wheel tires are 11L x 15 x 8 ply and properly inflated. Refer to *Tire Inflation Chart*, "Appendix," page 84 of the operator's manual.
4. Place several pounds of fertilizer over three fertilizer feed cups on outside end of drill box. Pull fertilizer tubes off of these three disk openers.
5. Weigh an empty container large enough to hold fertilizer applied to one acre.
6. Turn drive wheel until fertilizer starts to drop to ground.
7. Place container under the three tubes to gather metered fertilizer.
8. Turn drive wheel 130 rotations until one acre has been tallied on acremeter. Check that feed cups have plenty of fertilizer coming into them.
9. Weigh metered material. Subtract weight of empty container. Divide by three. Multiply by number of openers on your drill to determine total pounds metered per acre. If this figure is different than desired, reset sprockets accordingly.

NOTE: You may want to repeat calibration procedure if your results vary greatly from fertilizer rate chart.

10. When satisfied with metering rate, install same range, driver and driven sprockets on other drill box.
11. When drilling, check metering rate by noting acres drilled, amount of fertilizer added to drill and level of material in drill box. If you are applying more or less fertilizer than desired, adjust metering rate slightly to compensate for field conditions.

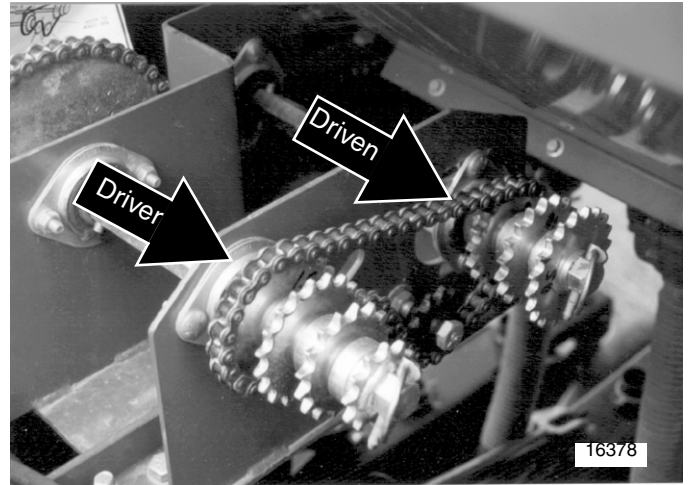

**Figure 6**  
**Driver/Driven Sprockets**

## Fertilizer Meter Rate Charts

Based on 65 pounds-per-cubic-foot density

6-Inch Rows

Meter Rate kg per ha	Meter Rate lb. per acre	Sprockets		
		Range	Driver	Driven
47	42	Low	12 T	21 T
50	44	Low	12 T	20 T
53	47	Low	12 T	19 T
55	49	Low	12 T	18 T
59	52	Low	12 T	17 T
62	55	Low	12 T	16 T
68	60	Low	17 T	21 T
71	63	Low	17 T	20 T
74	66	Low	17 T	19 T
79	70	Low	20 T	21 T
88	78	Low	21 T	20 T
92	82	Low	21 T	19 T
97	86	Low	21 T	18 T
103	91	Low	21 T	17 T
109	97	Low	21 T	16 T
118	105	Low	17 T	12 T
125	111	Low	18 T	12 T
131	116	High	12 T	21 T
132	117	Low	19 T	12 T
137	122	High	12 T	20 T
139	123	Low	20 T	12 T
144	128	High	12 T	19 T
146	130	Low	21 T	12 T
152	135	High	12 T	18 T
161	143	High	12 T	17 T
185	164	High	17 T	21 T
194	172	High	17 T	20 T
204	181	High	17 T	19 T
217	193	High	20 T	21 T
240	213	High	21 T	20 T
252	224	High	21 T	19 T
266	236	High	21 T	18 T
282	250	High	21 T	17 T
323	287	High	17 T	12 T
341	303	High	18 T	12 T
361	320	High	19 T	12 T
380	337	High	20 T	12 T
398	353	High	21 T	12 T

7 1/2-Inch Rows

Meter Rate kg per ha	Meter Rate lb. per acre	Sprockets		
		Range	Driver	Driven
38	34	Low	12 T	21 T
41	36	Low	12 T	20 T
42	37	Low	12 T	19 T
44	39	Low	12 T	18 T
47	42	Low	12 T	17 T
50	44	Low	12 T	16 T
54	48	Low	17 T	21 T
56	50	Low	17 T	20 T
60	53	Low	17 T	19 T
63	56	Low	20 T	21 T
70	62	Low	21 T	20 T
73	65	Low	21 T	19 T
78	69	Low	21 T	18 T
82	73	Low	21 T	17 T
88	78	Low	21 T	16 T
95	84	Low	17 T	12 T
100	89	Low	18 T	12 T
105	93	High	12 T	21 T
106	94	Low	19 T	12 T
109	97	High	12 T	20 T
110	98	Low	20 T	12 T
116	103	Low	21 T	12 T
116	103	High	12 T	19 T
122	108	High	12 T	18 T
130	115	High	12 T	17 T
148	131	High	17 T	21 T
155	138	High	17 T	20 T
163	145	High	17 T	19 T
174	154	High	20 T	21 T
192	170	High	21 T	20 T
202	179	High	21 T	19 T
213	189	High	21 T	18 T
225	200	High	21 T	17 T
259	230	High	17 T	12 T
274	243	High	18 T	12 T
288	256	High	19 T	12 T
303	269	High	20 T	12 T
319	283	High	21 T	12 T

10-Inch Rows

Meter Rate kg per ha	Meter Rate lb. per acre	Sprockets		
		Range	Driver	Driven
28	25	Low	12 T	21 T
30	27	Low	12 T	20 T
32	28	Low	12 T	19 T
34	30	Low	12 T	18 T
35	31	Low	12 T	17 T
37	33	Low	12 T	16 T
41	36	Low	17 T	21 T
43	38	Low	17 T	20 T
45	40	Low	17 T	19 T
47	42	Low	20 T	21 T
53	47	Low	21 T	20 T
55	49	Low	21 T	19 T
59	52	Low	21 T	18 T
62	55	Low	21 T	17 T
65	58	Low	21 T	16 T
71	63	Low	17 T	12 T
74	66	Low	18 T	12 T
79	70	Low	19 T	12 T
79	70	High	12 T	21 T
82	73	High	12 T	20 T
83	74	Low	20 T	12 T
87	77	High	12 T	19 T
88	78	Low	21 T	12 T
91	81	High	12 T	18 T
97	86	High	12 T	17 T
112	99	High	17 T	21 T
116	103	High	17 T	20 T
123	109	High	17 T	19 T
131	116	High	20 T	21 T
144	128	High	21 T	20 T
151	134	High	21 T	19 T
160	142	High	21 T	18 T
169	150	High	21 T	17 T
194	172	High	17 T	12 T
205	182	High	18 T	12 T
216	192	High	19 T	12 T
228	202	High	20 T	12 T
239	212	High	21 T	12 T

### Density Conversion Chart

The fertilizer meter rate charts are based on fertilizer with a density of 65 pounds per cubic foot. If you are applying fertilizer of a different density, use the following table to convert application rate.

Density	45.00	50.00	55.00	60.00	65.00	70.00	75.00	80.00
Conversion Factor	1.45	1.30	1.20	1.10	1.00	0.93	0.87	0.81

Example: Your fertilizer has a density of 75 pounds per cubic foot, and you want to apply 100 pounds per acre. Multiply desired application rate by the conversion factor.

$$100 \times 0.87 = 87$$

Adjust drill to setting closest to 87 pounds per acre.