

Assembly Instructions for the Ridge Splitter

Verti-Till

9/23/03

Your initial action is to bolt the angled drop stubs [(3) 589-147H] to the back 4x4 tube on the Verti-Till using 5/8x4x5 ½ U-Bolts [(63) 806-184C] 5/8" hex nuts [(25) 803-021C] and 5/8" lock washers [(26) 804-022C]. Be sure to place them as shown on the overhead layout. Do not tighten these bolts at this time. Your next step is to U-Bolt the splitter shank tube(s) [(1) 589-077D or 589-081D] to the drop stubs. Be sure everything is placed with the correct dimensions and tighten everything down at this time.

Your spring shank should come to you pre-assembled, so installation of these should be fairly straightforward. Take the shank mount plate off of the assembly and bolt the spring shank assembly to the splitter shank tube. Space the spring shank assemblies out as shown on the overhead layout and tighten bolts.

GREAT PLAINS MFG, INC
VT5300 RIDGE SPLITTER ATTACHMENT

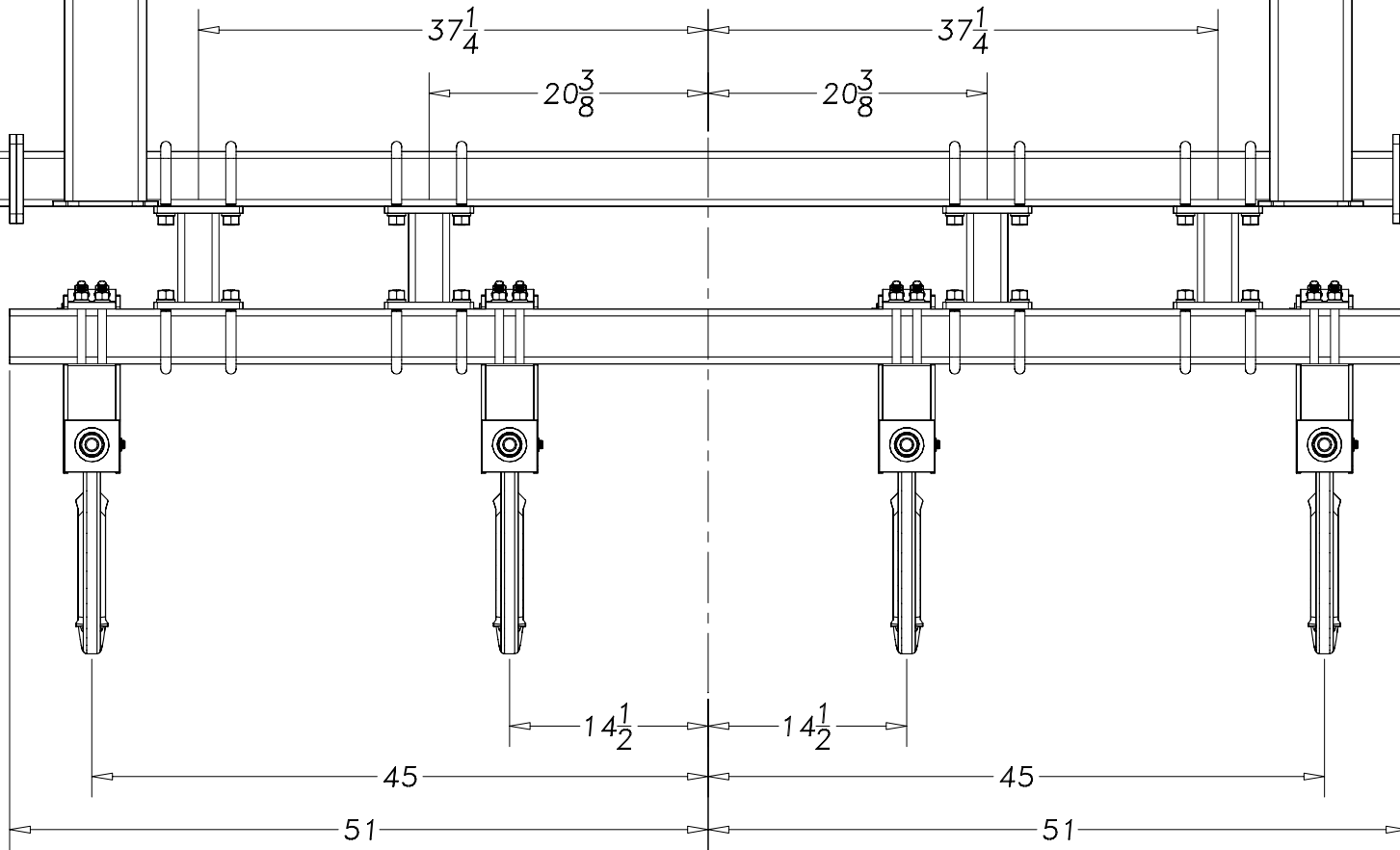

GREAT PLAINS MFG, INC
RIDGE SPLITTER ATTACHMENT

09/23/03

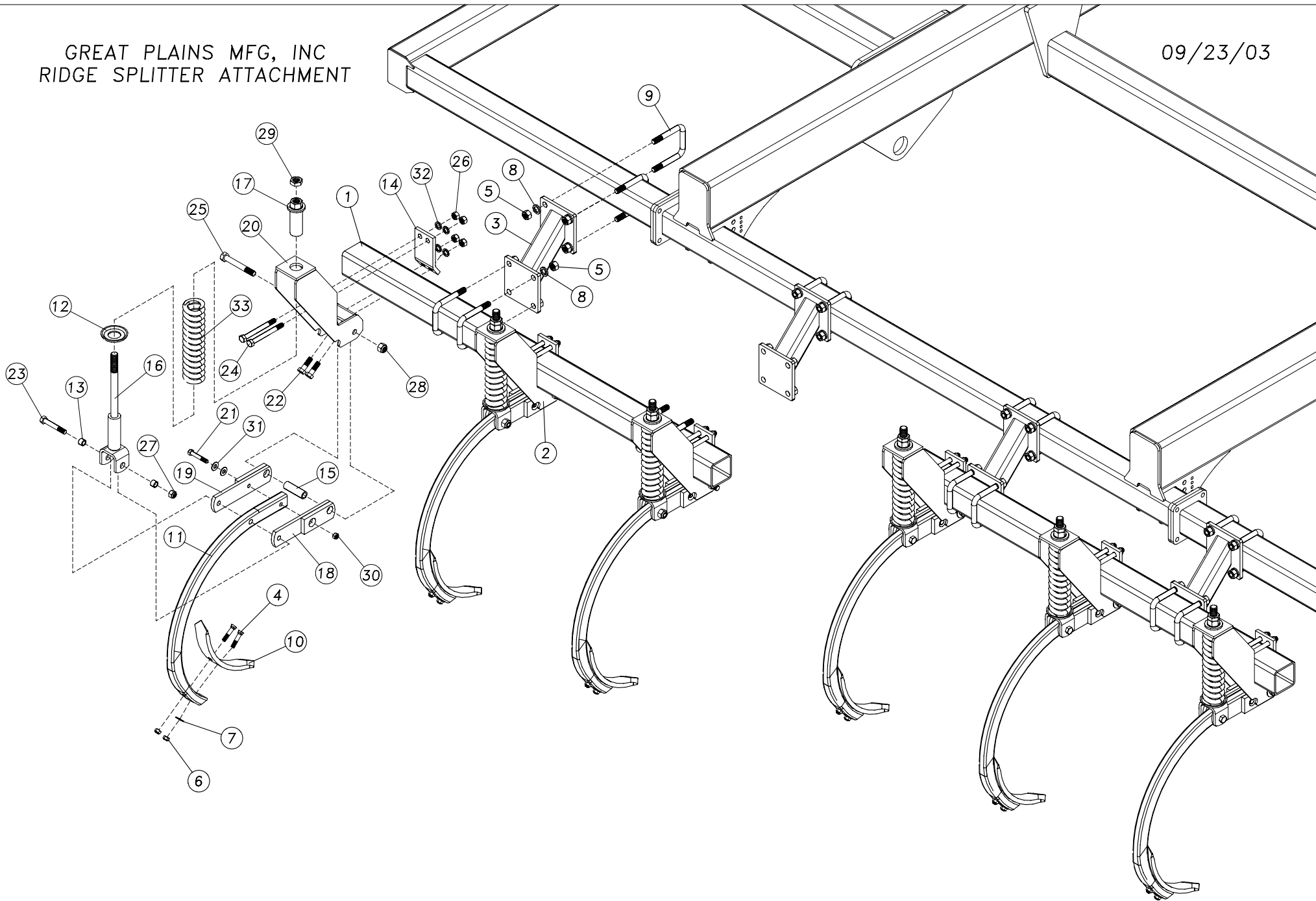

FOR PARTS AND ASSEMBLY REFERENCE ONLY



**VERTI-TILL FINISHING ATTACHMENTS
RIDGE SPLITTER**

REF #	DESCRIPTION	PART NO.	VT5300	VT7300
RIDGE SPLITTER PARTS LIST				
1	72" SPLITTER SHANK TUBE	589-077D		2
	102" SPLITTER SHANK TUBE	589-081D	1	
2	SPRING SHANK ASSEMBLY	589-136S	4	6
3	ANGLED DROP STUB	589-147H	4	4
4	PLOW 1/2-10X2 1/2 GR5	802-590C	8	12
5	NUT HEX 3/4-10 PLT	803-027C	32	32
6	NUT HEX TOP LOCK 1/2-13 PLT	803-342C	8	12
7	WASHER FLAT 1/2 USS PLT	804-017C	4	6
8	WASHER LOCK SPRING 3/4 PLT	804-023C	32	32
9	U-BOLT 3/4-10X4 1/32X5 3/8	806-012C	16	16
10	CHISEL POINT 5/8X2X15	820-032C	4	6
(INDIVIDUAL PARTS INCLUDED IN (589-136S) SPRING SHANK ASSEMBLY)				
11	MAX MULCHER SHANK	MC0013	1	1
12	CUP WASHER	589-065D	1	1
13	SHANK BOLT SPACER	589-070D	2	2
14	SHANK MOUNT PLATE	589-071D	1	1
15	SHANK PIVOT BUSHING	589-072D	1	1
16	SHANK SPRING BOLT	589-131H	1	1
17	SHANK SPRING BOLT TIGHTENER	589-132H	1	1
18	SHANK CRADLE RH	589-133H	1	1
19	SHANK CRADLE LH	589-134H	1	1
20	SHANK UPRIGHT	589-135H	1	1
21	HHCS 1/2-13X3 GR5	802-039C	1	1
22	HHCS 5/8-11X2 GR5	802-055C	2	2
23	HHCS 5/8-11X4 GR5	802-060C	1	1
24	HHCS 5/8-11X6 GR5	802-116C	2	2
25	HHCS 3/4-10X5 1/2 GR5	802-594C	1	1
26	NUT HEX 5/8-11 PLT	803-021C	4	4
27	NUT LOCK 5/8-11 PLT	803-024C	1	1
28	NUT LOCK 3/4-10 PLT	803-026C	1	1
29	NUT HEX JAM 1-8 PLT	803-030C	1	1
30	NUT HEX TOP LOCK 1/2-13 PLT	803-342C	1	1
31	WASHER FLAT 1/2 USS PLT	804-017C	2	2
32	WASHER LOCK SPRING 5/8 PLT	804-022C	4	4
33	SPRING COMP 3.13OD .63W 14.0LG	807-217C	1	1