

Operator's/Parts Manual

13' End Wheel Drill
Manual Marker

Great Plains

Manufacturing, Inc.

P.O. Box 5060 • Salina, Kansas 67402-5060



Read the Operator's manual entirely. When you see this symbol, the subsequent instructions and warnings are serious - follow without exception. Your life and the lives of others depend on it!

Great Plains



General Information

Important Notice

Great Plains Manufacturing, Inc. provides this publication "as is" without warranty of any kind, either expressed or implied, while every precaution has been taken in the preparation of this manual, Great Plains Manufacturing, Inc. assumes no responsibility for errors or omissions. Neither is any liability assumed for damages resulting from the use of the information contained herein. Great Plains Manufacturing, Inc. reserves the right to revise and improve its products as it sees fit. This

publication describes the state of this product at the time of its publication, and may not reflect the product at all times in the future.

Printed in the United States of America.

For your convenience, record your Serial Number, Model Number and the Date Purchased, of your drill, in the spaces provided below. Have this information before you when calling a Great Plains Authorized Dealer.

Owner's Information

Name: _____

Address _____

Address _____

City _____ State ____ Zip _____

City _____ State ____ Zip _____

Phone _____

Phone _____

Model Number _____

Date Purchased _____

Name of Dealership _____

Dealer's Name _____

Using this Manual

For your safety and to help in developing a better understanding of your equipment we highly recommend that you read the operator sections of this manual. Reading these sections not only provides valuable training but also familiarizes you with helpful information and its lo-

cation. The parts sections are for reference only and don't require cover to cover reading. After reviewing your manual store it in a dry, easily accessible location for future reference.

Table of Contents

Introduction	1	Maintenance	5
Section 1 Safety Rules	2	Marker Transporting	5
General Operation & Repair	2	Disk Bearings	5
Transporting	2	Section 4 Troubleshooting	5
Section 2 Assembly Instructions & Set-Up	2	Section 5 Parts	6
End Wheel Marker Installation Instructions	2	Manual Marker Assembly	6
Torque Values Chart for UNC Threads	4	Disk Assembly	8
Section 3 Maintenance & Lubrication	5		

Introduction

This manual has been prepared to instruct you in the safe and efficient operation of your End Wheel Marker. Read and follow all instructions and safety precautions carefully.

The parts on your End Wheel Marker have been specially designed and should only be replaced with genuine Great Plains parts. Therefore, should your End Wheel Marker require replacement parts go to your Great Plains Dealer.

The right hand and left hand as used throughout this manual is determined by facing in the direction the machine will travel when in use unless otherwise stated.



The SAFETY ALERT SYMBOL indicates that there is a potential hazard to personal safety involved and extra safety precautions must be taken. When you see this symbol, be alert and carefully read the message that follows it. In addition to design and configuration of equipment; hazard control and accident prevention are dependent upon the awareness, concern, prudence and proper training of personnel involved in the operation, transport, maintenance and storage of equipment.

Watch for the following safety notations throughout your Operators Manual:



DANGER!

Indicates an imminently hazardous situation which, if not avoided, will result in death or serious injury. This signal word is limited to the most extreme situations.



WARNING!

Indicates a potentially hazardous situation which, if not avoided, could result in death or serious injury.



CAUTION!

Indicates a potentially hazardous situation which, if not avoided, may result in minor or moderate injury. It may also be used to alert against unsafe practices.

Note: Indicates a special point of information which requires your attention.

Section 1 Safety Rules

Most accidents are the result of negligence and carelessness, usually caused by failure of the operator to follow simple but necessary safety precautions. The following safety precautions are suggested to help prevent such accidents. The safe operation of any machinery is a big concern to consumers and manufacturers. Your End Wheel Marker has been designed with many built-in safety features. However, no one should operate this product before carefully reading this Operators Manual.

General Operation & Repair

1. *Never allow the Manual Marker to be operated by anyone who is unfamiliar with the operation of all functions of the unit. All operators should read and thoroughly understand the instructions given in this manual prior to moving the unit.*
2. *Make sure safety rules are understood before operating machinery or tractor.*
3. *Never permit any persons other than the operator to ride on the tractor.*
4. *Never permit any persons to stand near the Manual Marker while it is in operation.*
5. *Regulate your speed to the field conditions, maintaining complete control at all times.*
6. *After repairing or adjusting, make sure all tools and parts are removed from the implement before attempting to operate it.*
7. *Do not grease or oil machine while it is in operation.*
8. *Loose fitting clothing should not be worn as it may catch in moving parts.*
9. *Never dismount from a moving tractor.*
10. *Do not leave the tractor or the implement unattended with the engine running.*
11. *Do not stand between the tractor and the implement during hitching.*
12. *Detach and store implements in an area where children normally do not play. Stabilize implements by using suitable supports and block wheels.*
13. *If a hydraulic leak develops, correct it immediately. Escaping hydraulic oil can have extremely high pressure. A stream of high pressure oil may easily penetrate the skin as with modern needle-less vaccination equipment - but with the exception that hydraulic fluid may cause blood poisoning. It is imperative that the connections are tight and that all lines and pipes are in good condition. If an injury is caused by the escaping hydraulic fluid, see doctor at once!*
14. *Use a piece of cardboard or wood to detect leaks of hydraulic oil under pressure.*
15. *Be sure to relieve all hydraulic pressure before disconnecting any lines or pipes between the implement and the tractor hydraulic system. Keep all guards and shields in place.*

Transporting

1. *Use good judgement when transporting tractor and implements on the highway. Always maintain complete control of the machine.*
2. *Limit transport speed to 20 mph. Transport only with a farm tractor of sufficient size and horse power.*
3. *Always make sure flashing safety lights, "Slow Moving Vehicle" emblem, and reflectors are in place and visible prior to transporting the machine on public roads.*
4. *Know your state and local laws concerning highway safety and regulations. Comply with these laws when transporting machinery.*
5. *Use warning flags or approved warning lights at night and during other periods of poor visibility. Do your best to prevent highway accidents*

Section 2 Assembly Instructions & Set-Up

End Wheel Marker Installation Instructions

Refer to Figure 2-1 for Installation Instructions.

Your marker system comes to you from Great Plains pre-assembled except for installing it on the drill and a few minor adjustments.

1. Attach marker hinge angles, (#1) & (#2), to the front box end panel through existing holes using (6) 1/2" x

1" long carriage bolts, lock washers, and nuts with support angle (#3), bolted on inside using the three in-line mounting holes as shown in Figure 2-1

2. Adjust the cutting angle of the disk blade by loosening the two locking bolts, (#5) at the end of the marker tube and rotate disk in or out as needed. At the same time this is being done, you will need to adjust the in and out position of the disk from the drill to your desired mark width and tighten locking bolts (#4) as shown.

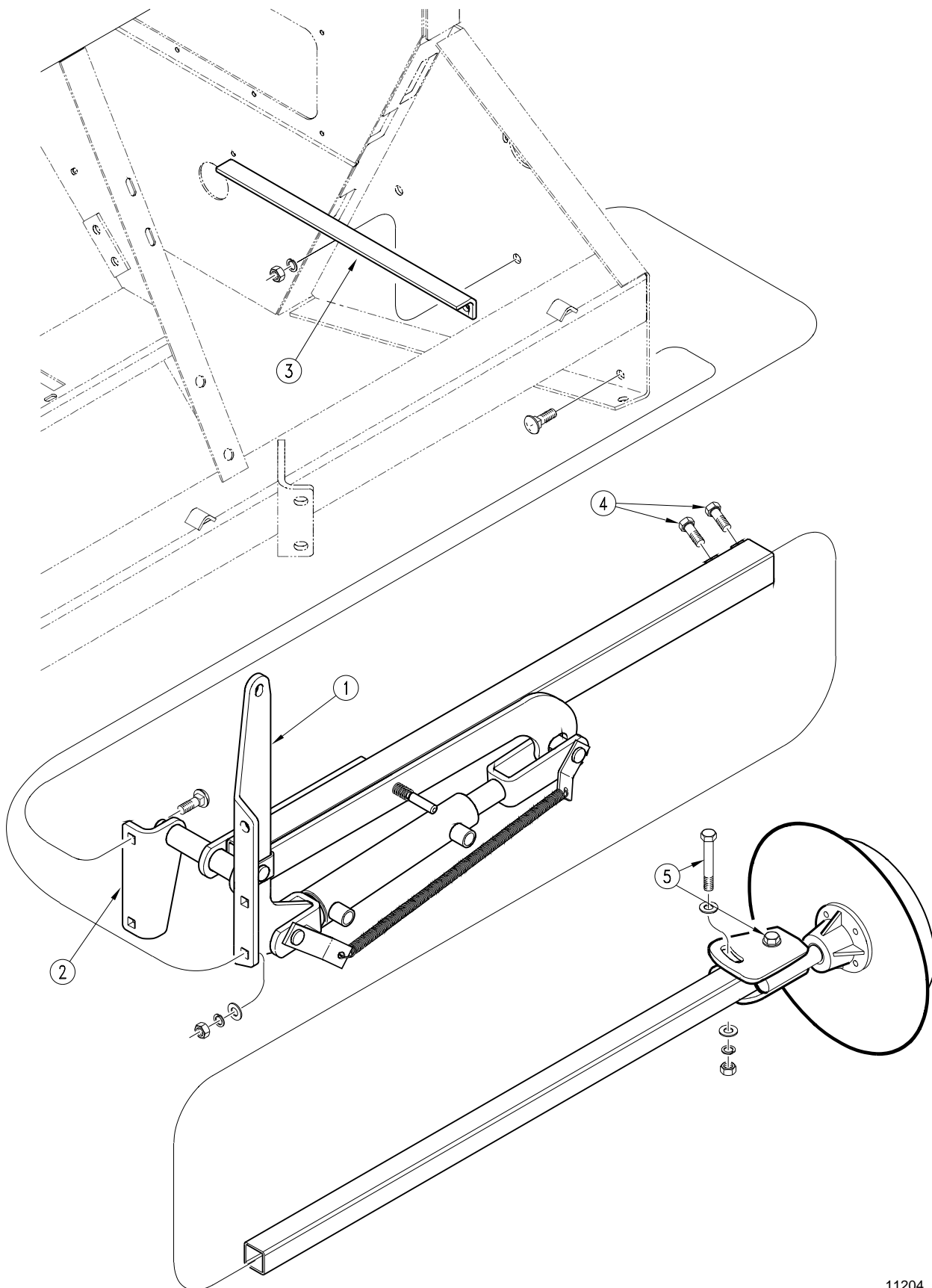

Assembly Diagram
Figure 2-1

11204



CAUTION!







Never allow anyone near the drill when cycling the marker!



WARNING!

Always pin marker up for safe transporting!

Torque Values Chart for UNC Threads

Bolt Size (Inches)	Bolt Head Identification						Bolt Size (Metric)	Bolt Head Identification					
													
	Grade 2		Grade 5		Grade 8			Class 5.8		Class 8.8		Class 10.9	
in-tpi ¹	N · m ²	ft-lb ³	N · m	ft-lb	N · m	ft-lb	mm x pitch ⁴	N · m	ft-lb	N · m	ft-lb	N · m	ft-lb
1/4" - 20	7.4	5.6	11	8	16	12	M 5 X 0.8	4	3	6	5	9	7
1/4" - 28	8.5	6	13	10	18	14	M 6 X 1	7	5	11	8	15	11
5/16" - 18	15	11	24	17	33	25	M 8 X 1.25	17	12	26	19	36	27
5/16" - 24	17	13	26	19	37	27	M 8 X 1	18	13	28	21	39	29
3/8" - 16	27	20	42	31	59	44	M10 X 1.5	33	24	52	39	72	53
3/8" - 24	31	22	47	35	67	49	M10 X 0.75	39	29	61	45	85	62
7/16" - 14	43	32	67	49	95	70	M12 X 1.75	58	42	91	67	125	93
7/16" - 20	49	36	75	55	105	78	M12 X 1.5	60	44	95	70	130	97
1/2" - 13	66	49	105	76	145	105	M12 X 1	90	66	105	77	145	105
1/2" - 20	75	55	115	85	165	120	M14 X 2	92	68	145	105	200	150
9/16" - 12	95	70	150	110	210	155	M14 X 1.5	99	73	155	115	215	160
9/16" - 18	105	79	165	120	235	170	M16 X 2	145	105	225	165	315	230
5/8" - 11	130	97	205	150	285	210	M16 X 1.5	155	115	240	180	335	245
5/8" - 18	150	110	230	170	325	240	M18 X 2.5	195	145	310	230	405	300
3/4" - 10	235	170	360	265	510	375	M18 X 1.5	220	165	350	260	485	355
3/4" - 16	260	190	405	295	570	420	M20 X 2.5	280	205	440	325	610	450
7/8" - 9	225	165	585	430	820	605	M20 X 1.5	310	230	650	480	900	665
7/8" - 14	250	185	640	475	905	670	M24 X 3	480	355	760	560	1050	780
1" - 8	340	250	875	645	1230	910	M24 X 2	525	390	830	610	1150	845
1" - 12	370	275	955	705	1350	995	M30 X 3.5	960	705	1510	1120	2100	1550
1-1/8" - 7	480	355	1080	795	1750	1290	M30 X 2	1060	785	1680	1240	2320	1710
1 1/8" - 12	540	395	1210	890	1960	1440	M36 X 3.5	1730	1270	2650	1950	3660	2700
1 1/4" - 7	680	500	1520	1120	2460	1820	M36 X 2	1880	1380	2960	2190	4100	3220
1 1/4" - 12	750	555	1680	1240	2730	2010							
1 3/8" - 6	890	655	1990	1470	3230	2380							
1 3/8" - 12	1010	745	2270	1670	3680	2710							
1 1/2" - 6	1180	870	2640	1950	4290	3160							
1 1/2" - 12	1330	980	2970	2190	4820	3560							

¹ in-tpi = bolt size in inches-threads per inch

² N · m = newton-meters

³ ft-lb= foot pounds

⁴ mm x pitch = millimeters x thread pitch

Section 3 Maintenance & Lubrication

Maintenance

Proper servicing and adjustment is the key to the long life of any farm implement. With careful and systematic inspection, you can avoid costly maintenance, time and repair.

Marker Transporting

Always transport the marker with it folded in the upright position.

Lubrication

Universal Lubrication Symbols

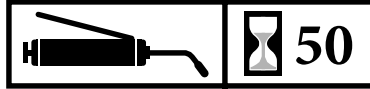

Lubrication is required every 50 hours of operation.



Use a multipurpose spray lub. Use as required. Do not over lubricate.

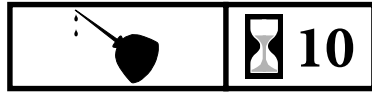

Lubrication is required every 10 hours of operation.

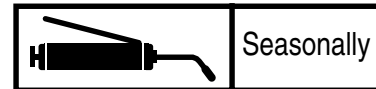

Lubrication is required _____.

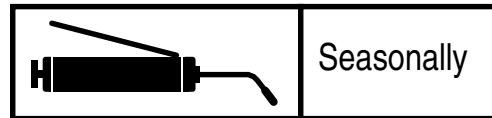
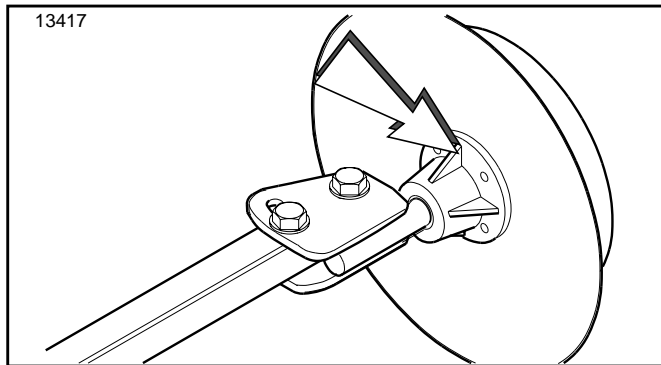

Disk Bearings

Type of Lubrication: Grease

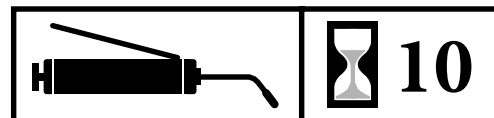
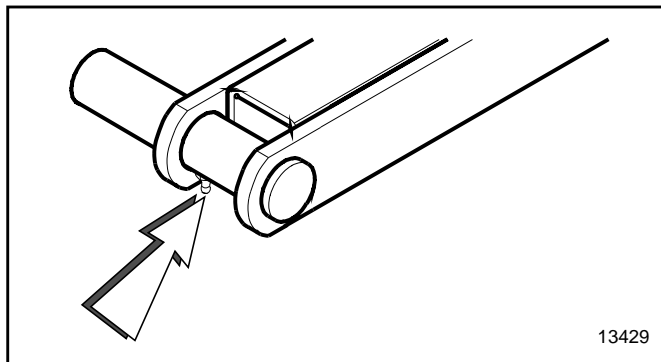

Pivot Zerk

Type of Lubrication: Grease

Section 4 Troubleshooting

	Solution
Blade does not mark	The blade may be reversed to pull dirt in or throw dirt out depending on soil conditions.

Great Plains Manufacturing, Inc.
Corporate Offices: PO. Box 218
Assaria, Kansas 67416 USA
