

Operators/Parts Manual

3-Point Solid Stand Drills
Stand Up Markers

Great Plains

Manufacturing, Inc.

P.O. Box 5060 • Salina, Kansas 67402-5060



Read the Operator's manual entirely. When you see this symbol, the subsequent instructions and warnings are serious - follow without exception. Your life and the lives of others depend on it!

Great Plains



General Information

Important Notice

Great Plains Manufacturing, Inc. provides this publication "as is" without warranty of any kind, either expressed or implied. While every precaution has been taken in the preparation of this manual, Great Plains Manufacturing, Inc. assumes no responsibility for errors or omissions. Neither is any liability assumed for damages resulting from the use of the information contained herein. Great Plains Manufacturing, Inc. reserves the right to revise and improve its products as it sees fit. This publi-

cation describes the state of this product at the time of its publication, and may not reflect the product in the future.

Printed in the United States of America.

For your convenience, record your Serial Number, Model Number and the Date Purchased in the spaces provided below. Have this information available when calling your **Great Plains** Authorized Dealer.

This Operator's Manual applies to the Stand Up Markers for:

Part #	Description	Drill
113-124A	12' Dual Hydraulic Marker	12' 3-Point Solid Stand Drill
113-124A	14' Dual Hydraulic Marker	14' 3-Point Solid Stand Drill
113-124A	15' Dual Hydraulic Marker	15' 3-Point Solid Stand Drill
113-125A	20' Dual Hydraulic Marker	20' 3-Point Solid Stand Drill
113-127A	14' Dual Hydraulic Marker	27' 3-Point Solid Stand Drill
113-138A	30' Dual Hydraulic Marker	30' 3-Point Solid Stand Drill

Owner's Information

Name: _____

Phone _____

Address _____

Serial Number _____

City _____ State ____ Zip _____

Model Number _____

Phone _____

Date Purchased _____

Name of Dealership _____

Dealer's Name _____

Address _____

City _____ State ____ Zip _____

Table of Contents

Using this Manual	2	Hinges	6
Introduction	2	Disk Bearings	6
Section 1 Safety Rules	3	Section 5 Troubleshooting Guide	7
General Operation & Repair	3	Section 6 Marker & Disk Assemblies	8
Transporting	3	Folding Hydraulic Marker	
Safety Decals	3	{12', 14', & 15' Drills}	8
Section 2 Assembly Instructions & Set-Up	4	Folding Hydraulic Marker	
Torque Values Chart for UNC Threads	4	{20', 27', & 30' Drills}	10
Pre-Assembly Checklist	4	Marker Disk Assembly	12
Installation Instructions	5	Section 7 Hydraulics	14
Section 3 Operating Instructions	5	Single Marker Hydraulics	
Bleeding of the Hydraulics	5	{15' & 20' 3-Point Drills}	14
Marker Transporting	5	Dual & Single Marker Hydraulic	
Section 4 Maintenance & Lubrication	6	{27' & 30' 3-Point Drills} 1	6
General Maintenance	6	Dual Marker Hydraulics Used With	
Storage	6	CDH, CPH, & CC	18
Lubrication	6	Selector Sequence Valve {810-006C}	20

Using this Manual

For your safety and to help in developing a better understanding of your equipment we highly recommend that you read the operator sections of this manual. Reading these sections not only provides valuable training but also familiarizes you with helpful information and its lo-

cation. The parts sections are for reference only and don't require cover to cover reading. After reviewing your manual store it in a dry, easily accessible location for future reference.

Introduction

This manual has been prepared to instruct you in the safe and efficient operation of your **Stand Up Markers**. Read and follow all instructions and safety precautions carefully.

The parts on your **Stand Up Markers** have been specially designed and should only be replaced with genuine **Great Plains** parts. Therefore, should your **Stand Up Markers** require replacement parts go to your **Great Plains Dealer**.

The right hand and left hand as used throughout this manual is determined by facing in the direction the machine will travel when in use unless otherwise stated.



The SAFETY ALERT SYMBOL indicates that there is a potential hazard to personal safety involved and extra safety precautions must be taken. When you see this symbol, be alert and carefully read the message that follows it. In addition to design and configuration of equipment; hazard control and accident prevention are dependent upon the awareness, concern, prudence and proper training of personnel involved in the operation, transport, maintenance and storage of equipment.

Watch for the following safety notations through-out your Operators Manual:



DANGER!

Indicates an imminently hazardous situation which, if not avoided, will result in death or serious injury. This signal word is limited to the most extreme situations.



WARNING!

Indicates a potentially hazardous situation which, if not avoided, could result in death or serious injury.



CAUTION!

Indicates a potentially hazardous situation which, if not avoided, may result in minor or moderate injury. It may also be used to alert against unsafe practices.

Note: Indicates a special point of information which requires your attention.

Section 1 Safety Rules



Most accidents are the result of negligence and carelessness, usually caused by failure of the operator to follow simple but necessary safety precautions. The following safety precautions are suggested to help prevent such accidents. The safe operation of any machinery is a big concern to consumers and manufacturers. Your **Stand Up Markers** have been designed with many built-in safety features. However, no one should operate this product before carefully reading this Operators Manual.

General Operation & Repair

1. **NEVER** permit anyone near machinery while in operation.
2. Excessive speed can cause marker damage.
3. **NEVER** allow anyone to be near the drill when cycling the markers.
4. Reduce speed of the tractor when transporting over uneven or rough terrain. Avoid all chuck holes and washboard areas in roads.
5. Reduce speed of the tractor when transporting over hills or steep slopes.
6. **DO NOT** lubricate, adjust or repair the drill while it is in operation.
7. Use "Slow Moving Vehicle" emblem for warning vehicles approaching from the rear.
8. **DO NOT** permit smoking, sparks, or an open flame where combustible lubricants or liquids are being used.

9.  **CAUTION!** Escaping fluid under pressure can have sufficient force to penetrate the skin. Check all hydraulic lines and hoses **BEFORE** applying pressure. Fluid escaping from a very small hole can be almost invisible. Use paper or cardboard, **NOT BODY PARTS**, to check for suspected leaks. If injured, seek medical assistance from a doctor that is familiar with this type of injury. Foreign fluids in the tissue must be surgically removed within a few hours or gangrene will result.

Transporting



1. Use good judgement when transporting tractor and implements on the highway. Always maintain complete control of the machine.
2. Use warning flags or approved warning lights at night and during other periods of poor visibility. Do your best to prevent highway accidents.
3. When in transport, use accessory lights and devices for adequate warning to operators of other vehicles and use safety hitch chain. Comply with all Federal, State and Local laws when traveling on public roads.
4. Reduce speed of the tractor when transporting over hills or steep slopes.
5. Reduce speed of the tractor when transporting over uneven or rough terrain. Avoid all chuck holes and washboard areas in roads.



Safety Decals

1. Your **Stand Up Markers** come equipped with all safety decals in place. They were designed to help you safely operate your **Markers**. Read and follow their directions.
2. Keep safety decals clean and legible.
3. Replace all damaged or missing safety decals. To order new safety decals go to your **Great Plains Dealer** and refer to the parts section for safety decal package part number.
4. Replace these decals whenever they become worn or unreadable. To install new safety decals:
 - a. Clean the area the decal is to be placed
 - b. Peel backing from the decal. Press firmly on to surface being careful not to cause air bubbles under the decal.

Section 2 Assembly Instructions & Set-Up

Torque Values Chart for UNC Threads

Bolt Size (Inches)	Bolt Head Identification					
						
	Grade 2		Grade 5		Grade 8	
in-tpi ¹	N · m ²	ft-lb ³	N · m	ft-lb	N · m	ft-lb
1/4" - 20	7.4	5.6	11	8	16	12
1/4" - 28	8.5	6	13	10	18	14
5/16 - 18	15	11	24	17	33	25
5/16" - 24	17	13	26	19	37	27
3/8" - 16	27	20	42	31	59	44
3/8" - 24	31	22	47	35	67	49
7/16" - 14	43	32	67	49	95	70
7/16" - 20	49	36	75	55	105	78
1/2" - 13	66	49	105	76	145	105
1/2" - 20	75	55	115	85	165	120
9/16" - 12	95	70	150	110	210	155
9/16" - 18	105	79	165	120	235	170
5/8" - 11	130	97	205	150	285	210
5/8" - 18	150	110	230	170	325	240
3/4" - 10	235	170	360	265	510	375
3/4" - 16	260	190	405	295	570	420
7/8" - 9	225	165	585	430	820	605
7/8" - 14	250	185	640	475	905	670
1" - 8	340	250	875	645	1230	910
1" - 12	370	275	955	705	1350	995
1-1/8" - 7	480	355	1080	795	1750	1290
1 1/8" - 12	540	395	1210	890	1960	1440
1 1/4" - 7	680	500	1520	1120	2460	1820
1 1/4" - 12	750	555	1680	1240	2730	2010
1 3/8" - 6	890	655	1990	1470	3230	2380
1 3/8" - 12	1010	745	2270	1670	3680	2710
1 1/2" - 6	1180	870	2640	1950	4290	3160
1 1/2" - 12	1330	980	2970	2190	4820	3560

Bolt Size (Metric)	Bolt Head Identification					
						
	Class 5.8		Class 8.8		Class 10.9	
mm x pitch ⁴	N · m	ft-lb	N · m	ft-lb	N · m	ft-lb
M 5 X 0.8	4	3	6	5	9	7
M 6 X 1	7	5	11	8	15	11
M 8 X 1.25	17	12	26	19	36	27
M 8 X 1	18	13	28	21	39	29
M10 X 1.5	33	24	52	39	72	53
M10 X 0.75	39	29	61	45	85	62
M12 X 1.75	58	42	91	67	125	93
M12 X 1.5	60	44	95	70	130	97
M12 X 1	90	66	105	77	145	105
M14 X 2	92	68	145	105	200	150
M14 X 1.5	99	73	155	115	215	160
M16 X 2	145	105	225	165	315	230
M16 X 1.5	155	115	240	180	335	245
M18 X 2.5	195	145	310	230	405	300
M18 X 1.5	220	165	350	260	485	355
M20 X 2.5	280	205	440	325	610	450
M20 X 1.5	310	230	650	480	900	665
M24 X 3	480	355	760	560	1050	780
M24 X 2	525	390	830	610	1150	845
M30 X 3.5	960	705	1510	1120	2100	1550
M30 X 2	1060	785	1680	1240	2320	1710
M36 X 3.5	1730	1270	2650	1950	3660	2700
M36 X 2	1880	1380	2960	2190	4100	3220

¹ in-tpi = head size in inches-threads per inch

² N · m = newton-meters

³ ft-lb = foot pounds

⁴ mm x pitch = millimeters x thread pitch

Pre-Assembly Checklist

Check

- All major components
- Fasteners that were shipped with the Folding No-Till Drill.
NOTE: Some of the hardware from the factory has been installed in the location where it will be used.
- Have a minimum of 2 people at hand while assembling the **Stand Up Markers.**

- Have a fork lift or loader along with chains and safety stands ready for the assembly task.
- If you are unsure where a fastener is used, use the parts section of this manual to identify it. Be sure the part gets used in the correct location.

Installation Instructions

Refer to the parts section of this manual for visual representation of the parts and their locations.

1. Attach fittings to cylinder ports. Attach the needle valve and hoses to the cylinder fittings as shown in Fig.???. Route hoses down to the drill frame and along the back side of the drill frame tubes to the center of the drill.

Important: Before folding the marker, bleed all the air out of the hydraulic system. Refer to "Bleeding of the Hydraulics" on page 5.

2. To bleed the air out of the hydraulic system, remove

the marker cylinder pin from the rod end of the cylinder, support the cylinder with the base end pin and block supporting the body of the cylinder on the first marker section. Cycle the marker cylinder several times to work the air out of the system.

3. After all of the air is removed from the system, refer to Fig.??? and repin the cylinder with the clevis pin (#), 1/8" cotter pin (#), and 1" flat washers (#).
4. Referring to Fig.???, adjust the speed of the marker with the needle valve (#) to a low setting. Fold the marker up and down a few times and recheck for pinching and kinking of hoses. Reset folding speed with the needle valve to a safe speed.

Section 3 Operating Instructions

Bleeding of the Hydraulics

1. Be sure tractor hydraulic reservoir is full.

Note: Never attempt to bleed an O-ring type fitting. Instead, choose a pipe or JIC fitting nearby.

2. With the marker(s) in field position, crack the hydraulic hose fitting(s) located at the base end of the cylinder(s). With your tractor at an idle speed, activate your tractor hydraulic valve until hydraulic oil seeps out around the hose ends. Tighten the hose end fittings and repeat this process with the hose end fitting(s) located at the rod end of the cylinder(s). If dual markers are used with a sequence valve, follow the procedure above for one marker cylinder. Then crack the fittings on the back side of the sequence valve, activate the tractor hydraulics valve until hydraulic oil seeps out around the hose ends. Tighten the hose end fittings and repeat the complete process for the opposite marker cylinder.
3. Fold and unfold the marker(s) slowly in order to work all the air out of your marker hydraulics. Use caution when folding and unfolding the marker for the first time, and check for pinching and kinking of hoses.



CAUTION!

Never allow anyone near the drill when cycling the markers.

4. The marker hydraulic system is equipped with a needle valve to control how fast the marker operates. Systems without a sequence valve have needle valves at each cylinder. On systems with a sequence valve, the needle valve is built into the sequence valve body. There are two hex adjustment heads, one for each side of the drill. To adjust your markers, screw the needle valve in to adjust the marker speed to a low setting. Fold the marker up and down a few times and recheck for pinching and kinking of hoses. With the tractor engine at an oper-

ating rpm, adjust the needle valve to limit the marker to a safe operating speed. Excessive folding speeds can cause marker damage.



CAUTION!

Excessive folding speeds can cause marker damage!



WARNING!

Escaping Fluid under pressure can have sufficient force to penetrate the skin. Check all hydraulic lines and hoses before applying pressure. Fluid escaping from a very small hole can be almost invisible. Use paper or cardboard, not body parts, to check for suspected leaks. If injured, seek medical assistance from a doctor that is familiar with this type of injury. Foreign fluids in the tissue must be surgically removed within a few hours or gangrene will result.

General Notes

The markers cycle in the following sequence

- (1) Right Up, Left Up
- (2) Right Down, Left Up
- (3) Right Up, Left Up
- (4) Right Up, Left Down
- (5) Sequence Repeats

Note: JIC fittings do not require high torque. JIC and O-Ring fittings do not require sealant. Always use liquid pipe sealant when adding or replacing pipe thread fittings. To avoid possible danger of cracking hydraulic fittings from over tightening, DO NOT use plastic sealant tape.

Marker Transporting

Always transport the marker with it folded in the flat fold position. Make sure the second marker section(s) rests securely on the transport carrier(s).

Section 4 Maintenance & Lubrication

General Maintenance

1. After using your **Stand Up Markers** for several hours, check all bolts to be sure they are tight.
2. Replace any worn, damaged or illegible safety decals by obtaining new decals from your **Great Plains Dealer**.

Breakaway Protection

The marker arm is attached to the marker body with a 3/8" shear bolt. If excessive force is put on the marker during operation, the shear bolt will break, allowing the marker arm to swing away rather than cause damage to the marker.

Note: The breakaway bolt is a 3/8"-16 x 1 3/4" long - grade 2 (G.P. # 802-253C). It is identified as a grade 2 by having no marks on the head. If it breaks, it must be replaced by an equivalent grade 2 bolt to prevent marker damage.

Storage

3. Lubricate all pivots as indicated in the following instructions.
4. Store the **3-Point Drill** inside if possible for longer drill life.

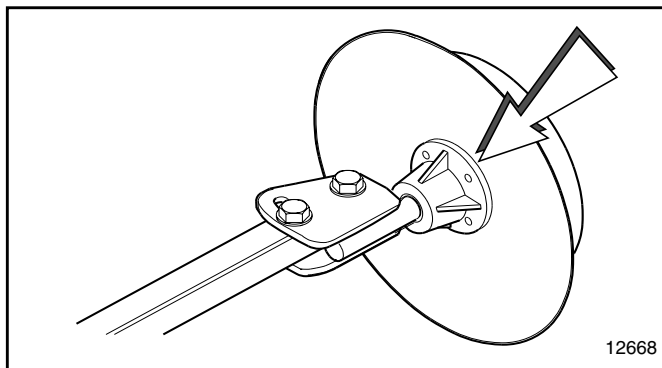
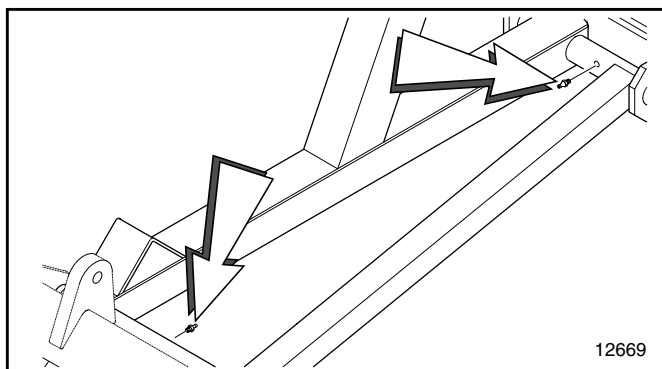

Lubrication

Lubrication Symbols



Lubrication is required every 50 hours of operation.



Lubrication is required every 10 hours of operation.



Use a multipurpose spray lube. Use as required. Do not over lubricate.

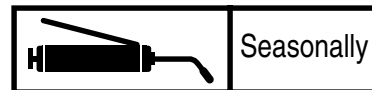

Lubrication is required

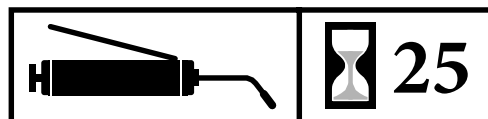

Hinges

The marker body hinge pivots require greasing every 20-25 hours of operation. Each marker has two grease fittings located at the center of each end of the first section.

Type of Lubrication: Grease

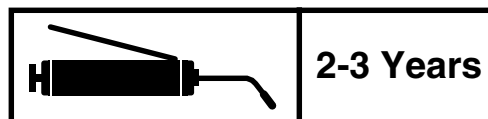

Disk Bearings

The tapered roller bearings in the disk hub are lubricated at the factory. Under normal conditions, the bearings need to be repacked every 2 to 3 years. If the grease seal or grease cap becomes damaged or is missing, the hub should be disassembled, cleaned and bearings repacked. A new seal or grease cap should be installed.

Type of Lubrication: Grease

Section 5 Troubleshooting Guide

Problem	Solution
Hydraulic Marker functioning improperly	<ul style="list-style-type: none">a. Check all hose fittings & connections for air and oil leaks.b. The chain on the folding marker should be slack when the marker is both fully extended and fully raised.c. Check tractor hydraulic oil level.d. Check all bolts and fasteners.e. If needle valve is plugged; open valve, cycle markers, and reset the needle valve.f. Double selector valve positioned for fold cylinders. Shift valve to marker sequence position.
Blade does not mark	<ul style="list-style-type: none">a. The marker folding linkage and chain must have enough slack to allow the marker disk to drop down into depressions in the field. Maximum down float should be limited by the slots at the rod end of the marker cylinder, and not by the chain. Read the adjustments section of this manual when adding slack to the chain.b. The blade may be reversed to pull dirt in or throw dirt out depending on soil conditions. See disk adjustments in this manual.c. An optional smooth blade is available through your Great Plains dealer. The notched blade comes with your marker as standard equipment.

Section 6 Folding Hydraulic Marker {12', 14', & 15' Drills}

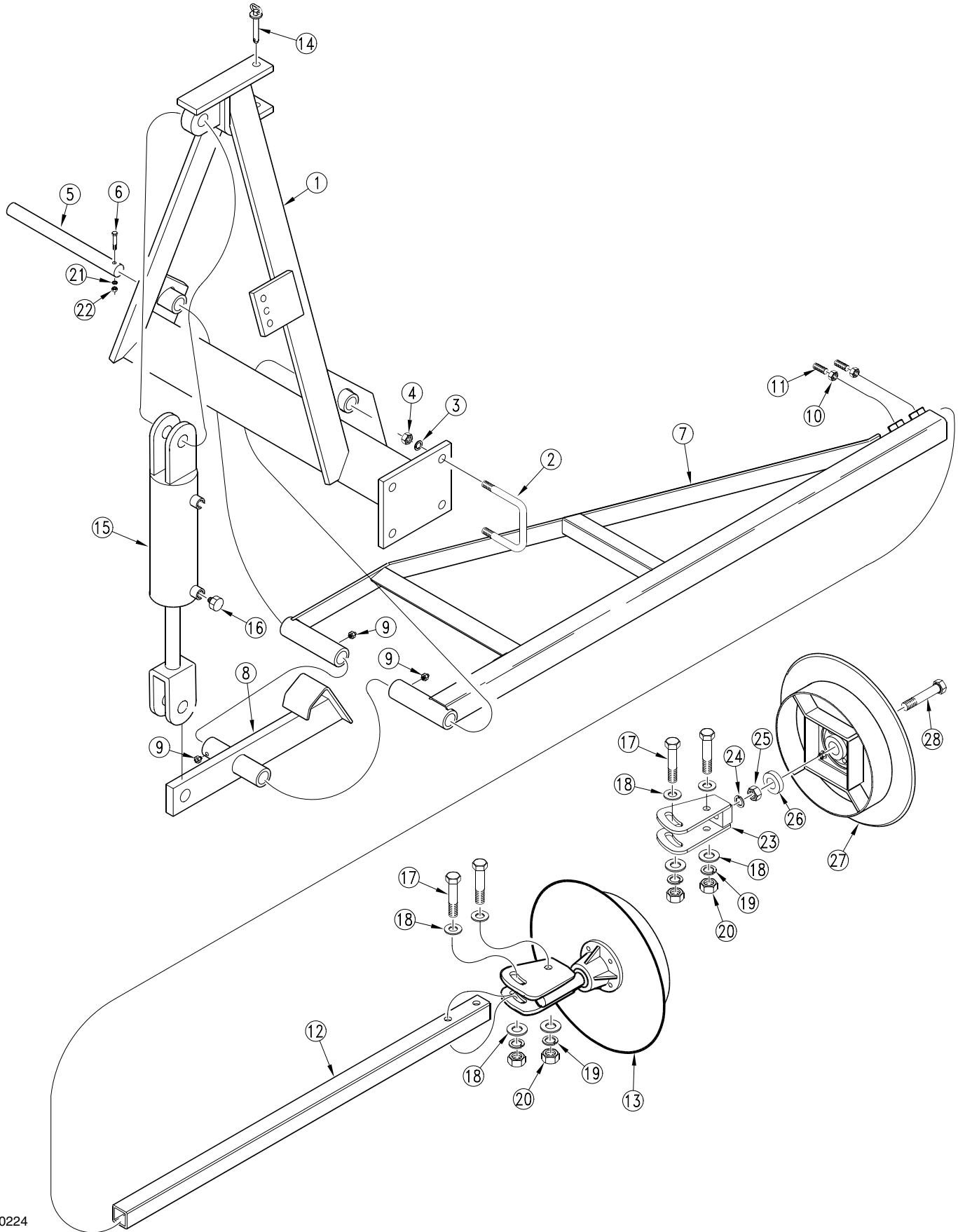

10224

Section 6 Folding Hydraulic Marker {12', 14', & 15' Drills}

Ref.	Part No.	Part Description
1.	113-060H	LH FOLDING MARKER MOUNT WELDMT
	113-061H	RH FOLDING MARKER MOUNT WELDMT
2.	806-006C	U-BOLT 5/8-11 X 3 17/32 X 5
3.	804-022C	WASHER LOCK SPRING 5/8 PLT
4.	803-021C	NUT HEX 5/8-11 PLT
5.	113-110D	MARKER BODY PIVOT
6.	802-152C	HHCS 1/4-20X2 GR5
7.	113-086H	12',14' & 15' LH MARKER EXT.
	113-085H	12',14' & 15' RH MARKER EXT.
8.	113-062H	MARKER LEVER ARM WELDMENT
9.	800-001C	GREASE ZERK STRAIGHT 1/4-28
10.	803-036C	NUT HEX JAM 1/2-13 PLT
11.	801-054C	SCREW SET SQ HD. 1/2-13X1 GR5
12.	113-353D	MARKER TUBE 51 LG
13.	113-563S	MARKER DISC & HUB ASSEMBLY
	113-364S	REPLACED BY 113-563S
14.	805-042C	PIN LOCK 1/2 X 3 1/2 USABLE LG
15.	810-005C	CYL 2X8X1.12 ROD SINGLE ACTING
16.	811-019C	PL 3/8MNPT BREATHER
17.	802-041C	HHCS 1/2-13X3 1/2 GR5
18.	804-017C	WASHER FLAT 1/2 USS PLT
19.	804-015C	WASHER LOCK SPRING 1/2 PLT
20.	803-020C	NUT HEX 1/2-13 PLT
21.	804-006C	WASHER LOCK SPRING 1/4 PLT
22.	803-006C	NUT HEX 1/4-20 PLT

Section 6 Folding Hydraulic Marker {20', 27', & 30' Drills}

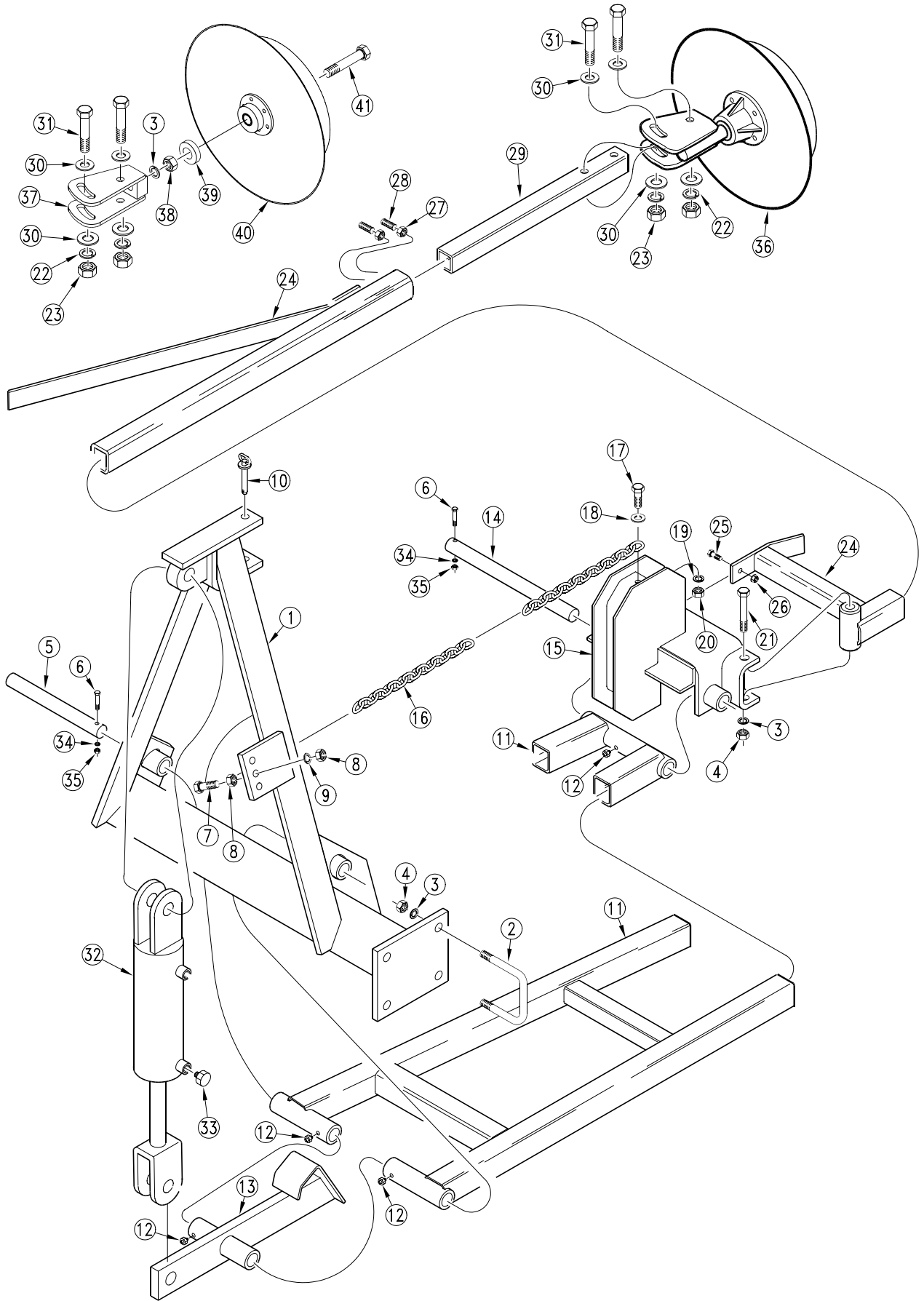

10227

Section 6 Folding Hydraulic Marker {20', 27', & 30' Drills}

Ref.	Part No.	Part Description
1.	113-061H	RH FOLDING MARKER MOUNT WELDMT
	113-060H	LH FOLDING MARKER MOUNT WELDMT
2.	806-006C	U-BOLT 5/8-11 X 3 17/32 X 5
3.	804-022C	WASHER LOCK SPRING 5/8 PLT
4.	803-021C	NUT HEX 5/8-11 PLT
5.	113-110D	MARKER BODY PIVOT
6.	802-152C	HHCS 1/4-20X2 GR5
7.	802-113C	HHCS 7/16-14X1 3/4 GR5
8.	803-015C	NUT HEX 7/16-14 PLT
9.	804-014C	WASHER LOCK 7/16 PLT
10.	805-042C	PIN LOCK 1/2 X 3 1/2 USABLE LG
11.	113-063H	MARKER ARM WELDMENT
12.	800-001C	GREASE ZERK STRAIGHT 1/4-28
13.	113-062H	MARKER LEVER ARM WELDMENT
14.	113-111D	HINGE PIVOT BAR
15.	113-066H	LH EXT PIVOT BRACKET WELDMENT
	113-067H	RH EXT PIVOT BRACKET WELDMENT
16.	113-148D	CHAIN 1/4 X 67 INCHES
	113-132D	CHAIN 1/4X94 INCHES PROOF PLT
17.	802-079C	HHCS 3/8-16X1 1/4 GR5
18.	804-011C	WASHER FLAT 3/8 USS PLT
19.	804-013C	WASHER LOCK SPRING 3/8 PLT
20.	803-014C	NUT HEX 3/8-16 PLT
21.	802-045C	HHCS 1/2-13X5 GR5
22.	804-015C	WASHER LOCK SPRING 1/2 PLT
23.	803-020C	NUT HEX 1/2-13 PLT
24.	113-083H	20' LH MARKER EXTENSION
	113-082H	20' RH MARKER EXTENSION
	113-064H	RH MARKER EXTENSION WELDMENT
	113-065H	LH MARKER EXTENSION WELDMENT
	802-159C	HHCS 5/16-18X1 GR5
25.	803-043C	NUT HEX WHIZ 5/16-18 PLT
26.	803-036C	NUT HEX JAM 1/2-13 PLT
27.	801-054C	SCREW SET SQ HD. 1/2-13X1 GR5
28.	113-355D	MARKER TUBE 57 LONG
29.	113-354D	13' MARKER TUBE 46 1/2 LONG
30.	804-017C	WASHER FLAT 1/2 USS PLT
31.	802-041C	HHCS 1/2-13X3 1/2 GR5
32.	810-005C	CYL 2X8X1.12 ROD SINGLE ACTING
33.	811-019C	PL 3/8MNPT BREATHER
34.	804-015C	WASHER LOCK SPRING 1/2 PLT
35.	803-020C	NUT HEX 1/2-13 PLT
36.	804-006C	WASHER LOCK SPRING 1/4 PLT
37.	803-006C	NUT HEX 1/4-20 PLT
38.	113-563S	MARKER DISC & HUB ASSEMBLY
	113-364S	REPLACED BY 113-563S

Section 6 Marker Disk Assembly

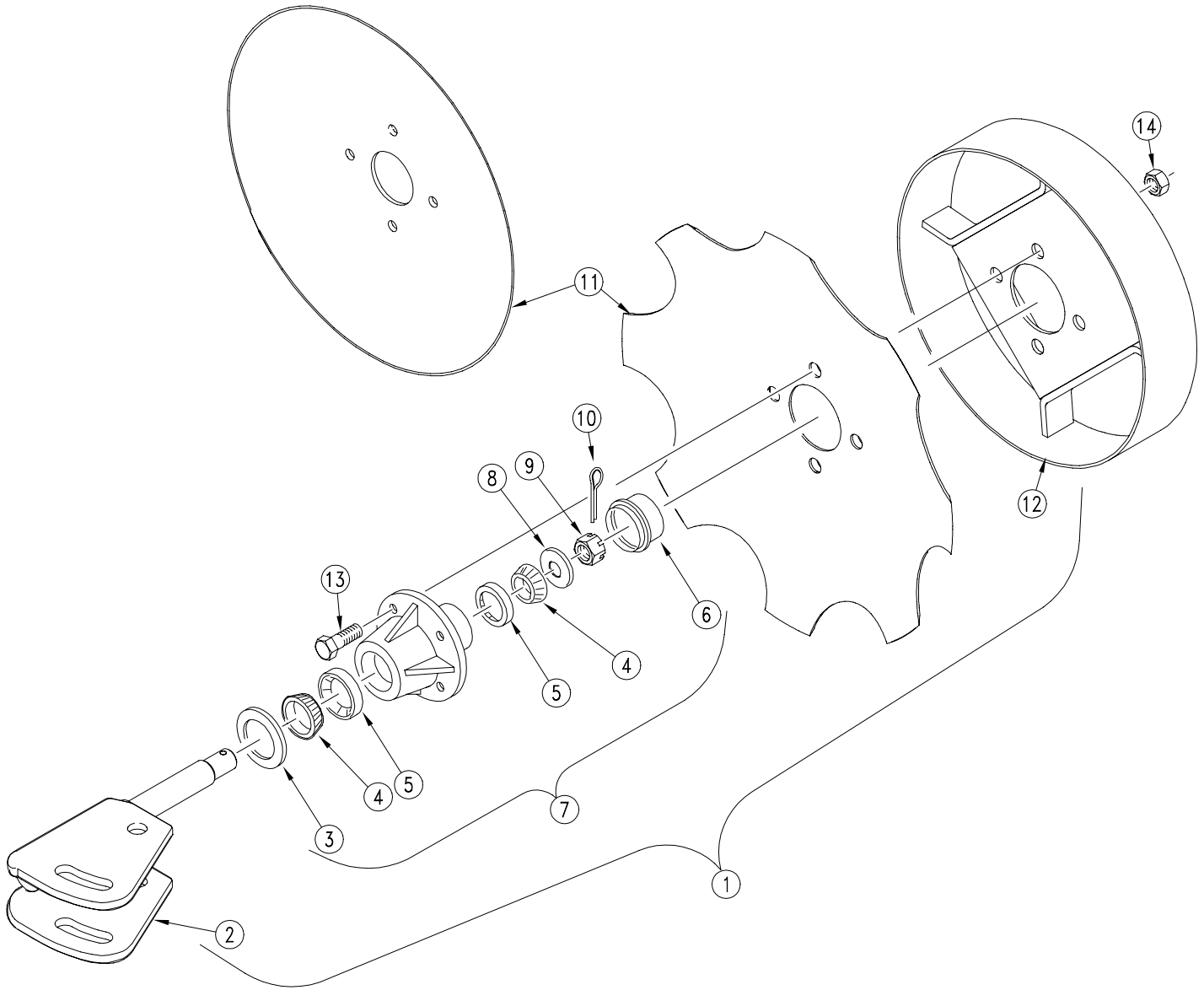

11244

Section 6 Marker Disk Assembly

Ref.	Part No.	Part Description
1.	113-563S	MARKER DISC & HUB ASSEMBLY
	113-564S	REP BY 113-563S
	113-372S	REP BY 113-564S
2.	113-562H	1 SPINDLE MARKER WELDMENT
3.	816-014C	TINE GAUGE WHEEL HUB SEAL
4.	822-030C	BEARING CONE L44643
5.	822-080C	BEARING CUP L44610
6.	890-614C	GREASE CAP #1505
7.	815-001C	TINE GW HUB
8.	804-025C	WASHER FLAT 3/4 SAE PLT
9.	803-053C	NUT HEX SLOTTED 3/4-16
10.	805-019C	PIN COTTER 5/32 X 1 PLT
11.	820-094C	16 4-BOLT NOTCHED MARKER DISK
	820-098C	14 4-BOLT MARKER DISK
12.	113-369H	DEPTH BAND 10 4-BOLT 4B.C.
13.	802-125C	LUG BOLT
14.	803-159C	NUT LUG 1/2-20 X 60 DEG PLT

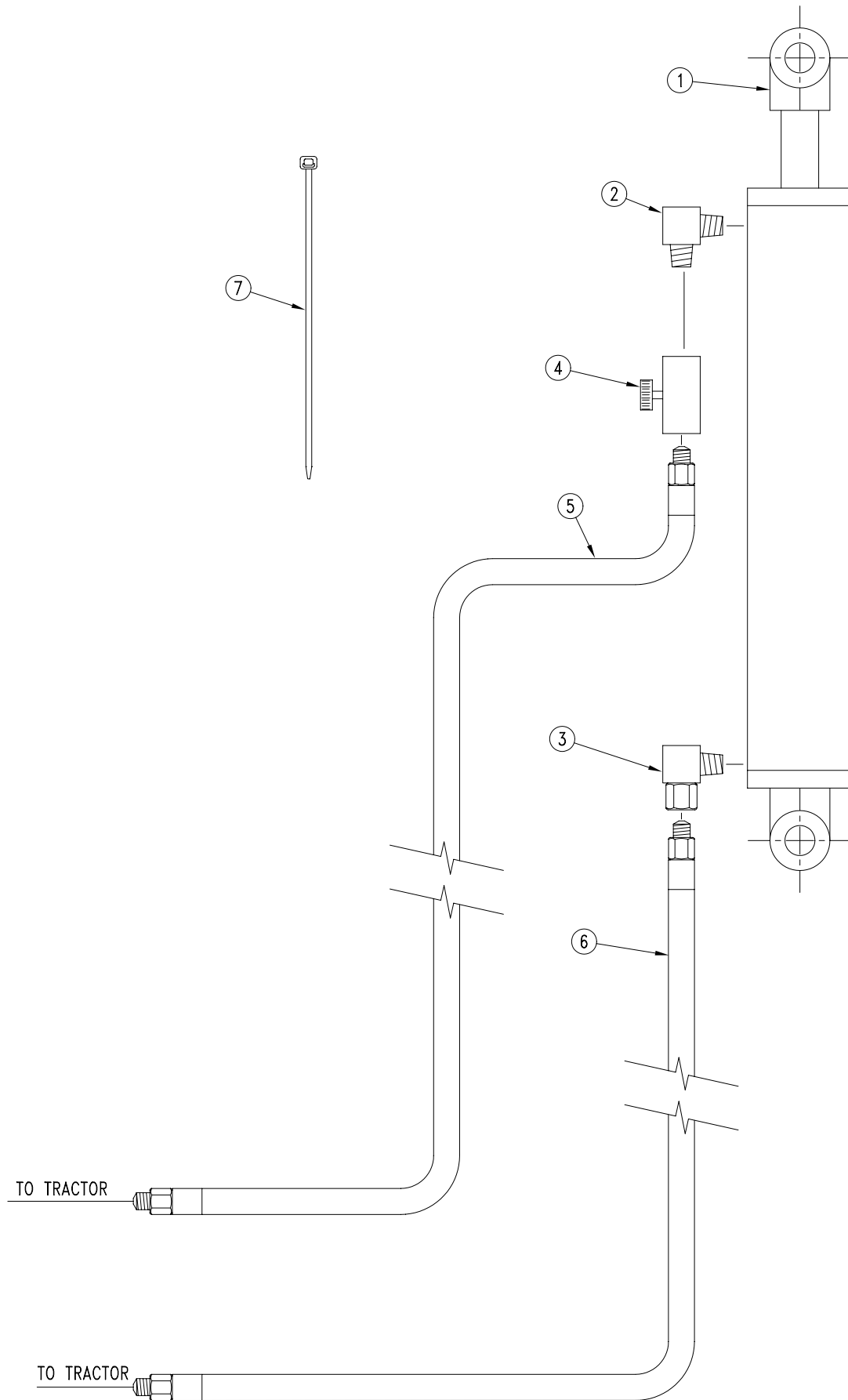

11383

Section 7 Single Marker Hydraulics {15' & 20' 3-Point Drills}

Ref.	Part No.	Part Description
1.	810-005C	Hydraulic Cylinder 2" x 8" Stroke
2.	811-156C	Elbow 3/8" MNPT
3.	811-026C	Elbow 3/8" MNPT x 3/8" FNPT
4.	810-058C	Needle Valve 3/8"
5.	811-015C	Hydraulic Hose 1/4" x 192" Long - 20' Drill
	811-017C	Hydraulic Hose 1/4" x 156" Long - 15' Drill
6.	811-297C	Hydraulic Hose 1/4" x 212" Long - 20' Drill
	811-300C	Hydraulic Hose 1/4" x 176" Long - 15' Drill
7.	800-082C	Cable Tie 21" Long

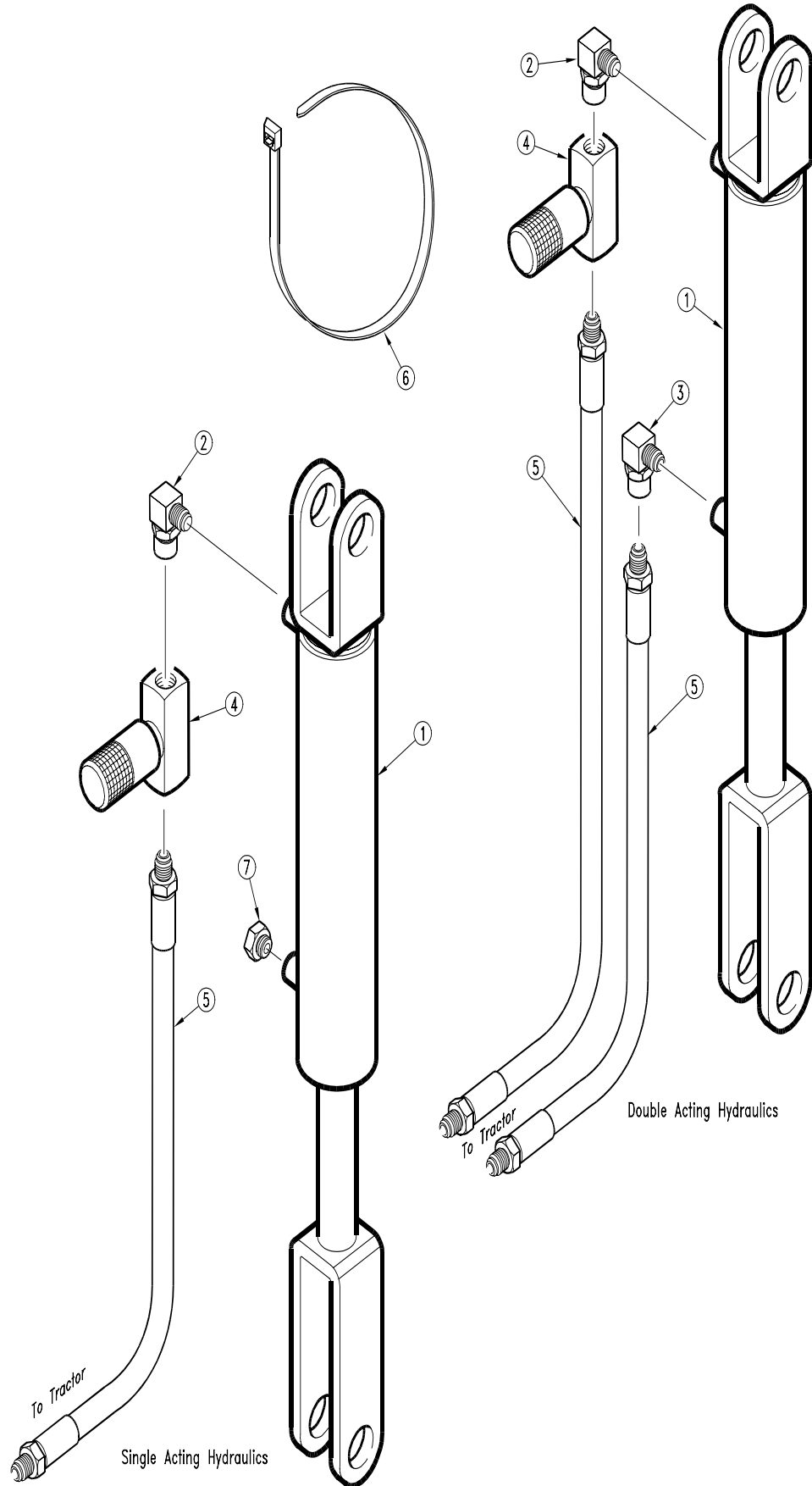

Section 7 Dual & Single Marker Hydraulic {27' & 30' 3-Point Drills}

Ref.	Part No.	Part Description
1.	810-005C	Hydraulic Cylinder 2" x 8" Stroke
2.	811-281C	Elbow 3/8" MNPT
3.	811-026C	Elbow 3/8" MNPT x 3/8" MNPT
4.	810-058C	Needle Valve 3/8"
5.	811-129C	Hydraulic Hose 1/4" x 234" Long 27' Drill
	811-058C	Hydraulic Hose 1/4" x 303" Long 30' Drill
6.	811-294C	Hydraulic Hose 1/4" x 254" Long 27' Drill
	811-299C	Hydraulic Hose 1/4" x 323" Long 30' Drill
7.	800-082C	Cable Tie 21" Long

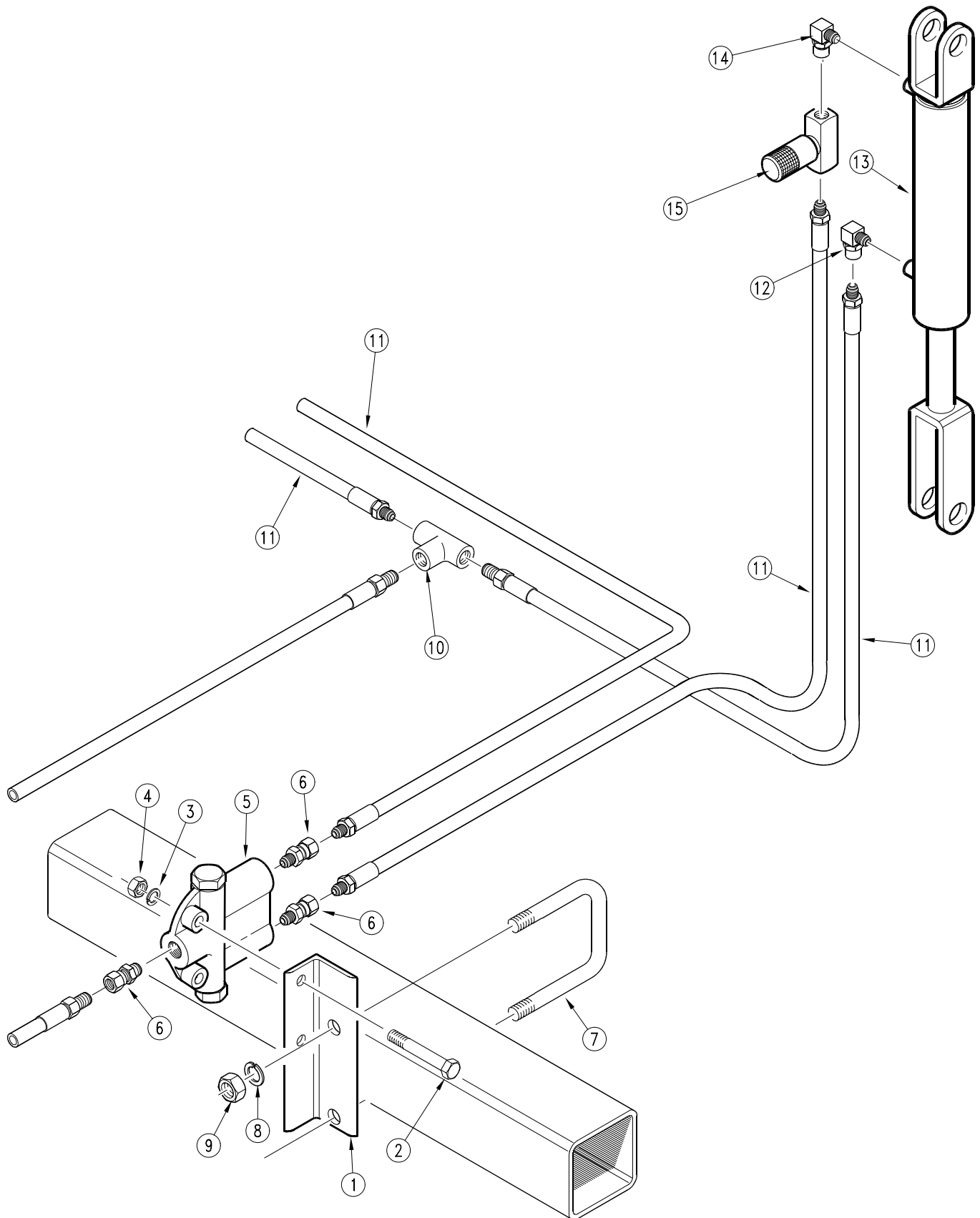

10258

Section 7 Dual Marker Hydraulics Used With CDH, CPH, & CC

Ref.	Part No.	Part Description
1.	113-263D	3-Point Sequence Valve Mount
2.	802-023C	Bolt, Hex 3/8"-16 x 1 3/4" Long
3.	804-013C	Washer, Lock 3/8"
4.	803-014C	Nut, Hex 3/8"-16
5.	810-006C	Sequence Valve
6.	811-021C	Hydraulic Fitting 1/2" FNPT Swivel x 3/4" MORB
7.	806-002C	U-Bolt 1/4"-13 x 3 1/2" x 4 1/2" Long
8.	804-015C	Washer, Lock 1/2"
9.	803-020C	Nut, Hex 1/2"-13
10.	811-009C	Hydraulic Fitting 1/2" FNPT Tee
11.	811-017C	Hydraulic Hose 1/4" x 156" Long {15' Drill}
	811-015C	Hydraulic Hose 1/4" x 192" Long {20' Drill}
12.	811-214C	Hydraulic Fitting 1/2" MNPT x 3/8" FNPT Street L
13.	810-005C	Hydraulic Cylinder 2" x 8" Stroke
14.	811-156C	Hydraulic Fitting Elbow 3/8" MNPT
15.	810-058C	Needle Valve 3/8"
	113-137A	3-Point Drill Marker Valve Kit for use with Combination Drill Hitch, Center Pivot Hitch and Coulter Caddy. Includes 1 Each of Items 1, 5, 7 & 10; 2 Each of Items 2 Through 4, 8 & 9; and 3 Each of Item 6.

Note: To avoid cracking the hydraulic fittings, **DO NOT** use plastic sealant tape. Use only liquid pipe sealant to seal the hydraulic fittings.

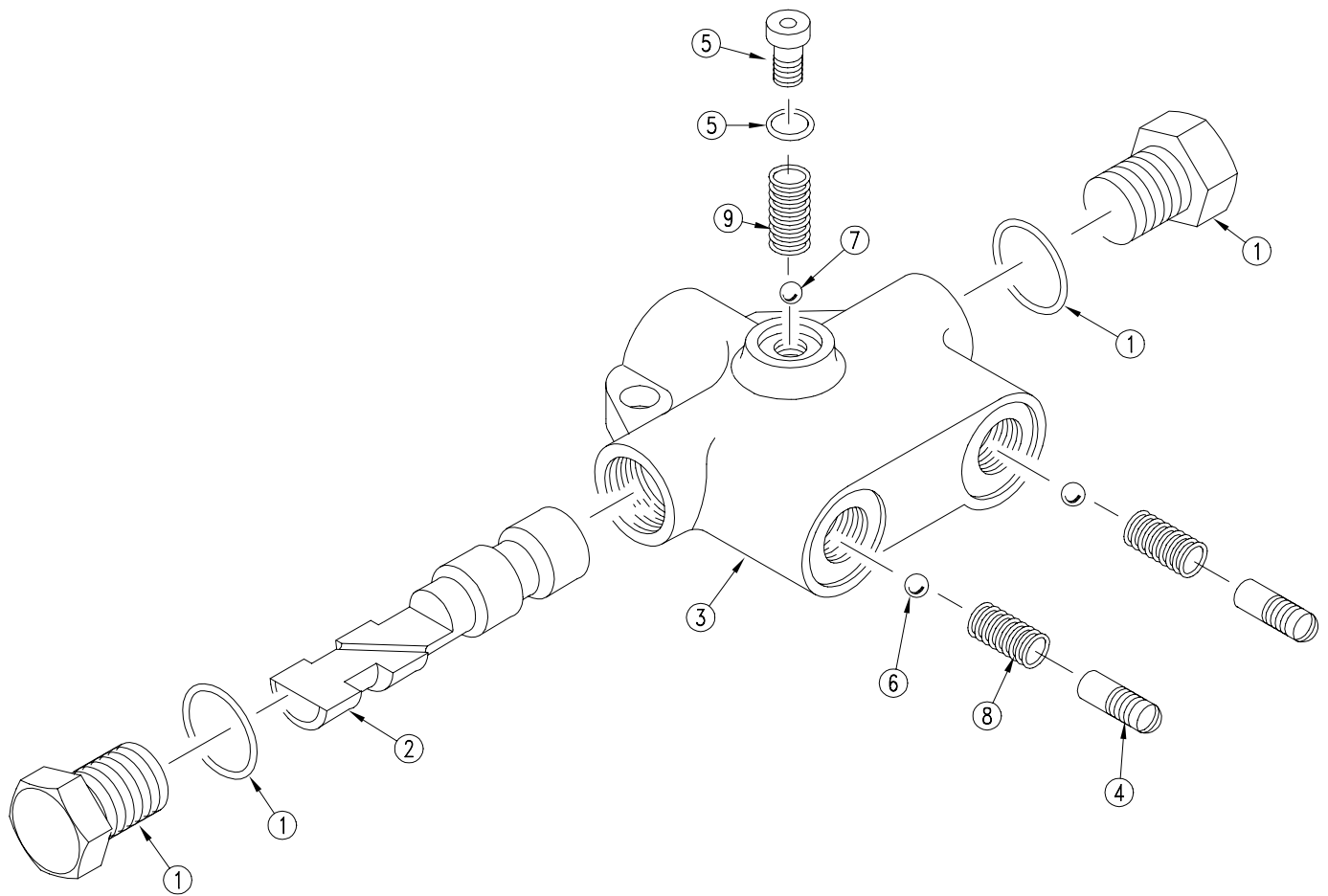

Section 7 Selector Sequence Valve {810-006C}

Ref.	Part No.	Part Description
1.	1V1880	O-Ring Boss Plug Assembly
2.	1V1882	Spool
3.	1V2003	Body Machining
4.	1V2003	Check Valve Retainer
5.	3-V4153-022	O-Ring Boss Plug Assembly
6.	2A0017-6	3/16" Ball
7.	2A0017-8	1/4" Ball
8.	2A9018-3	Check Valve Spring
9.	2A9024-1	Spring
	2A0353-12	Shipping Plug